

M-21-02
SEPTEMBER 2022

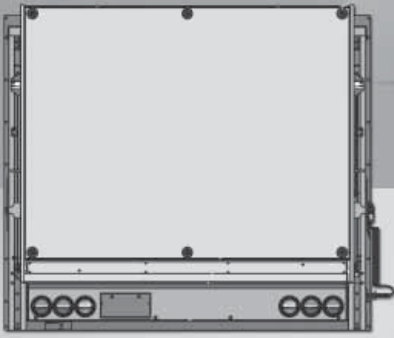

MAXON[®]

TOOL TRUCK

DMD-22

OPERATION MANUAL

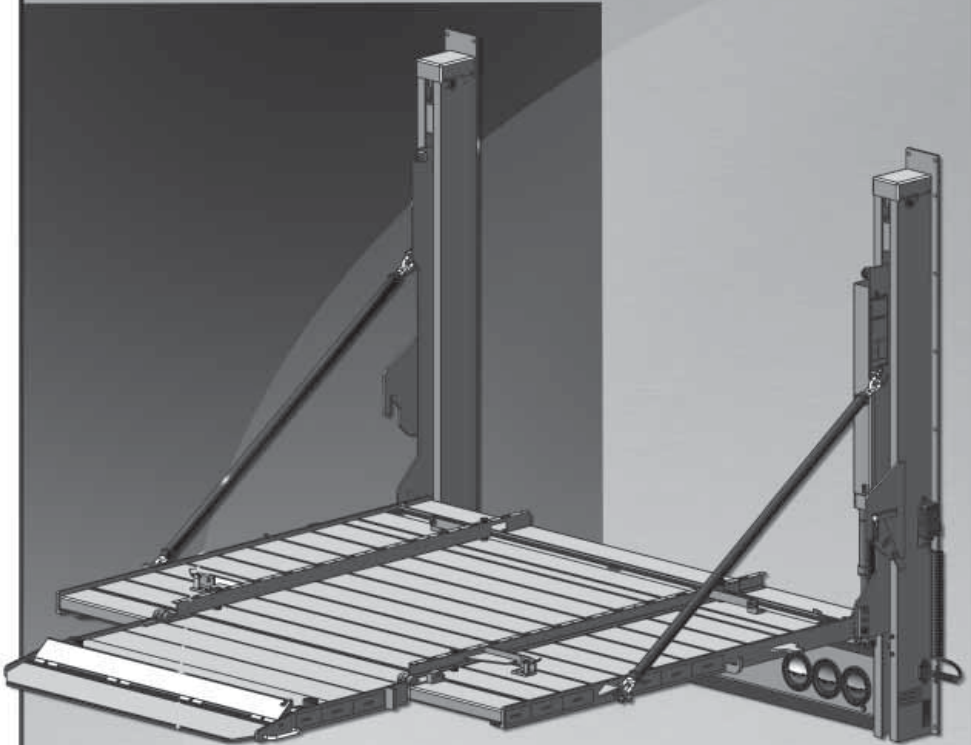

KEEP THIS MANUAL INSIDE OF VEHICLE

Register your liftgate online at <http://www.maxonlift.com/support/product-registration>. For a free copy of other manuals that pertain to these liftgate models, please visit our website at www.maxonlift.com or call Customer Service at (800) 227-4116.

To find **maintenance & parts** information for your **Tool Truck DMD Liftgate**, go to www.maxonlift.com. Click the **PRODUCTS, RAILIFT & DMD** buttons. Open the **Maintenance Manual** in the **PRODUCT DOCUMENTATION** window. For parts, click on the **PARTS PORTAL, RAILIFT & DMD** buttons.

TABLE OF CONTENTS

WARNINGS	4
LIFTGATE TERMINOLOGY	5
RECOMMENDED DAILY OPERATION CHECKS	6
DECALS	8
DECALS & PLATES	10
FORKLIFT ADVISORY	11
OPERATION	12
UNFOLDING THE PLATFORM.....	12
LOADING VEHICLE	16
LOWERING THE PLATFORM	16
POSITIONING LOAD	16
RAISING & UNLOADING PLATFORM.....	18
UNLOADING VEHICLE	20
POSITIONING LOAD	20
LOWERING & UNLOADING PLATFORM.....	24
STOWING PLATFORM	26

WARNING

1. Incorrect operation of this Liftgate can result in serious personal injury. Comply with **WARNINGS** and Liftgate operating instructions in this manual. Do not allow untrained persons or children to operate the Liftgate. If you need to replace an **Operation Manual**, additional copies are available from:

MAXON Lift Corp. Customer Service
11921 Slauson Ave
Santa Fe Springs, CA 90670
(800) 227-4116

2. Do not exceed rated **load capacity of 2200 lb for Tool Truck DMD-22 Liftgate.**
3. Do not allow any part of your body to be placed under, within, or around any portion of the moving Liftgate or its mechanisms, or in a position that would trap them between the platform and the floor of truck body (or between platform and the ground) when Liftgate is operated.
4. Consider the safety and location of bystanders and location of nearby objects when operating the Liftgate. Stand to one side of platform while operating the Liftgate. Be certain that the area the Liftgate will move through during operation is clear of all obstacles.
5. Comply with all attached instruction decals and warning decals.
6. Keep decals clean and legible. If decals are illegible or missing, have them replaced. **Get free replacement decals from Maxon.**
7. **Never drive a forklift on the Liftgate platform.**
8. Do not move vehicle unless Liftgate is correctly stowed.
9. **Correctly stow platform when not in use. Extended platforms could create a hazard for people and vehicles passing by.**
10. A correctly installed Liftgate will operate smoothly and reasonably quiet. The only noticeable noise during Liftgate operation is from the power unit while the platform is being lowered and raised. Listen for scraping, grating and binding noises and have the problem corrected before continuing to operate the Liftgate.
11. Above all, **USE GOOD COMMON SENSE** when operating this Liftgate.
12. Never use a cell phone while operating the Liftgate.

LIFTGATE TERMINOLOGY

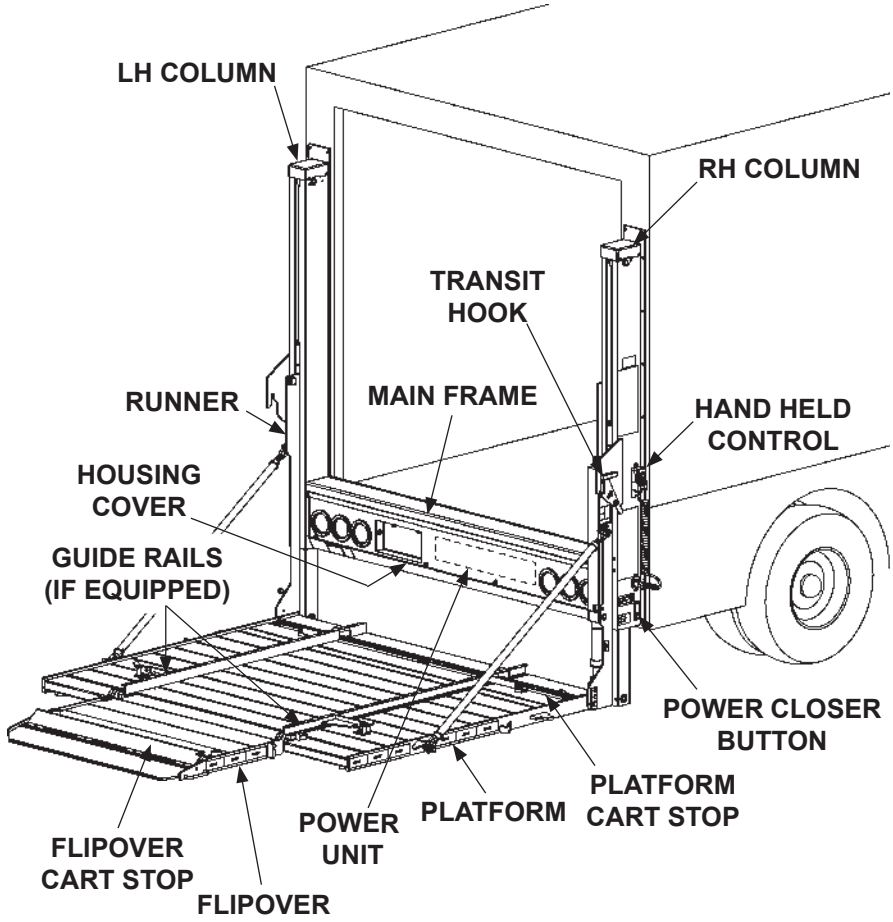

RECOMMENDED DAILY OPERATION CHECKS

NOTE: Before you check the Liftgate, park vehicle on flat ground and set the parking brake.

NOTE: If any of the following operation checks reveal a need to service or repair Liftgate, do not operate the Liftgate until a qualified mechanic services or repairs the Liftgate.

Before operating the Liftgate, the operator should do the following:

- Make sure batteries are fully charged, battery terminal connections are clean and tight, and battery box is undamaged.
- Make sure cab cutoff switch is **ON**, if equipped.
- Visually check that main frame housing cover is bolted on securely and undamaged. Look for hydraulic fluid leaks from main frame and columns.
- Follow the visible routing of hydraulic hoses from cylinders to main frame housing . Make sure all hoses are connected at both ends and there are no cracks, chafing, and fluid leaks.
- Visually check that handheld and power opener controls are in place and undamaged.
- Visually check that all decals are in place (see **DECALS** page). Make sure decals are legible, clean, and undamaged.

Use the operation instructions in this manual to unfold the platform.

- Position top surface of platform at vehicle bed level. Check if platform surface is even with liftgate main housing across the width of the platform. If platform is uneven, press **RAISE** button on control switch until platform stops. Hold for 10 seconds more to get platform even.
- Check for smooth operation as platform unfolds and as runners lower the platform to the ground.
- Check main frame housing, columns, runners and platform openers for cracks and bends. Make sure platform chains are undamaged and connected securely at both ends. Also, make sure all bolts and pins are in place and undamaged.
- Check platform and flipover for cracks, holes, and bends on the load-carrying surfaces and side plates. Also, make sure carts stops and guide rails are undamaged and are not missing parts.

Use the operation instructions in this manual to operate the Liftgate through one cycle without a load on the platform. Raise the platform to vehicle bed height. Next, lower the platform to ground level.

- When raising and lowering platform, listen for unusual noises and look for a “jerking” motion or uneven movement at LH and RH sides of the platform. Uneven movement should not exceed 1”.
- With platform at bed height, make sure the LH and RH platform chains feel even in tightness.
- Guide rail(s) release, rotate smoothly, and remain in positions until intentionally moved.
- Carts stops release, open, and close smoothly and remain so until intentionally opened or stowed.

If service or repairs are not required (or if completed), stow platform for transport.

OPERATING INSTRUCTIONS



Scan this QR code to see operation manual or video.

OPERATE

1. RAISE PLATFORM OFF TRANSIT HOOK.
2. LOWER TO UNLOCK.

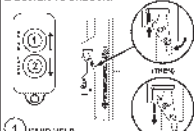

1 HAND-HELD CONTROLS

2. LOWER PLATFORM AT OR BELOW ARROW ALIGNMENT.

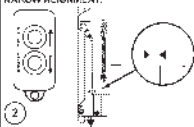

2

3. TO UNFOLD PLATFORM: PUSH POWER CLOSER BUTTON & LOWER BUTTON AT SAME TIME.

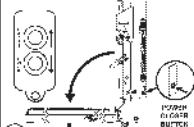

3

4. UNLOCK & UNFOLD FLIPOVER.

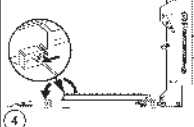

4

5. RAISE / LOWER PLATFORM.

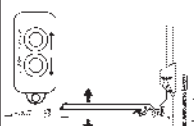

5

STOW

1. FOLD & LOCK FLIPOVER IF EQUIPPED.

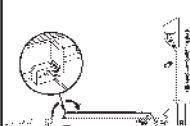

1

2. RAISE PLATFORM AT OR BELOW ARROW ALIGNMENT.

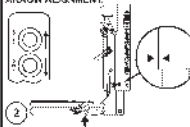

2

3. TO FOLD PLATFORM: PUSH POWER CLOSER BUTTON & RAISE BUTTON AT SAME TIME.

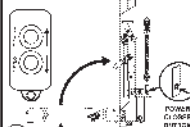

3

4. RAISE PLATFORM ABOVE TRANSIT HOOK.

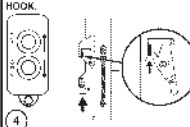

4

5. MAKE SURE TRANSIT HOOK RETURNS TO TRANSIT POSITION.

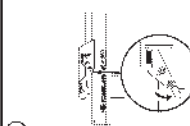

5

(B)



Align arrows before folding or unfolding.

2112 00101 ©

CAUTION

Always stand clear of platform area.



WARNING

Liftgate hazards can result in crushing or falling.

Keep hands and feet clear of pinch points.

If riding liftgate, make sure load is stable and footing is solid.

Read and understand all instructions and WARNINGS before use.

WARNING

Read this information carefully.

- Inappropriate use of this Liftgate can result in serious personal injury. If you do not have a copy of the operating instructions, please obtain them from your employer, distributor, or dealer before you attempt to operate the Liftgate.
- If there are signs of improper use, such as misuse, damage, or illegal parts, or improper platform surface, do not use the Liftgate until these problems have been corrected.
- If you are using a pallet jack, be sure it can be maneuvered safely.
- Do not operate a forklift on the platform.
- Do not allow any part of your or your helper's body, or be placed under, within, or around any portion of the moving liftgate, or be in its path when, or in a position that could trap, when between the platform and the ground or truck when the liftgate is operated.
- If a helper is riding the platform with you, make sure you are both doing so safely and that you are not in range of crushing or contact with any moving or potentially moving obstacle.
- USE GOOD COMMON SENSE
- If rain appears to be unsafe, do not lift or lower it.

For a full copy of the manual, the dealer at the model of this product, visit our website at www.manitou.com or call Customer Services at (800) 735-5166.

SAFETY INSTRUCTIONS

Read all decals and operation manuals before operating liftgate.

1. Do not use liftgate unless you have been properly instructed and have read and understood all of the operating instructions.
2. Reuse liftgate only when it is properly and securely parked before using the liftgate.
3. Always inspect the liftgate for maintenance or damage before using it. Do not use liftgate if it shows any sign of damage or improper maintenance.
4. Do not overload.
5. Keep clear the area in which the platform will open and close & clear before opening or closing the platform.
6. Make certain platform area, including the area in which cars may fall from platform, is clear before use at all times during operation of liftgate.
7. This liftgate is intended for use only on a surface of concrete. Do not use this liftgate on anything but the intended use.

21121600-01 (A)

DECAL SHEET
P/N 211630-01

DECALS & PLATES

NOTE: Preferred decal layout is shown. Decals on the Liftgate are attached at the factory, except for the 24/7 SUPPORT decal. The 24/7 SUPPORT decal is placed at customer's or installer's preference.



**MAXON 24/7
SUPPORT DECAL
P/N 298634-01**

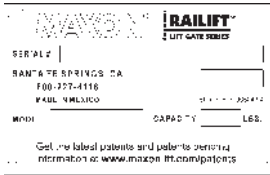

**SERIAL PLATE
(REF)**



**PARTS QR CODE
DECAL
P/N 299143-01**

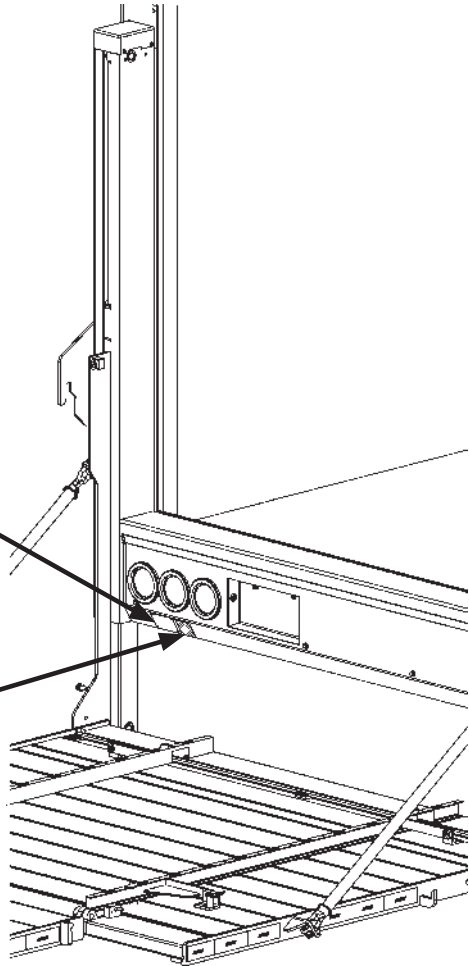

FIG. 10-1

FORKLIFT ADVISORY

⚠ WARNING
Keep forklift OFF of platform.

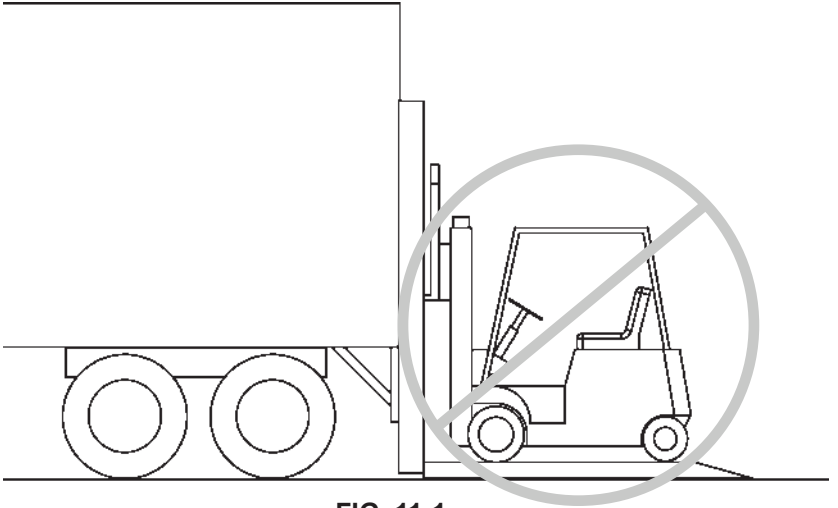

FIG. 11-1

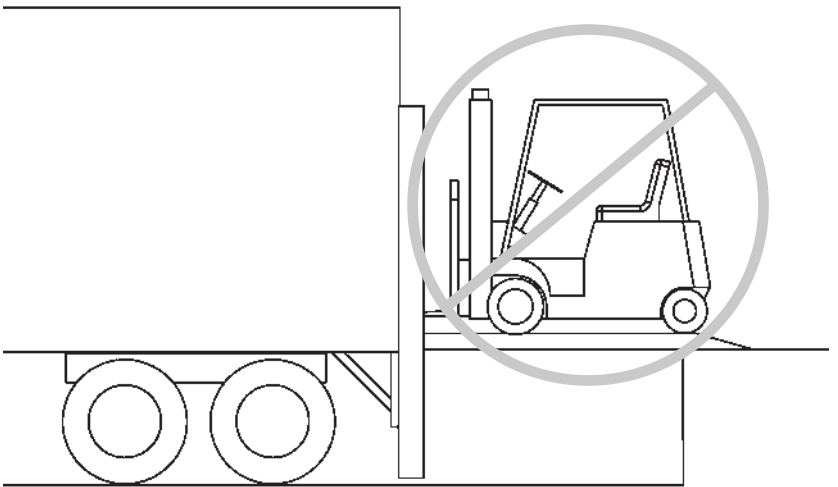

FIG. 11-2

OPERATION

UNFOLDING THE PLATFORM

NOTE: Do **RECOMMENDED DAILY OPERATION CHECKS** at the beginning of this manual.

1. Raise platform stop off transit hook (FIGS. 12-1 and 12-1A) by pushing the control switch **UP** button (FIGS. 12-1 and 12-1B).

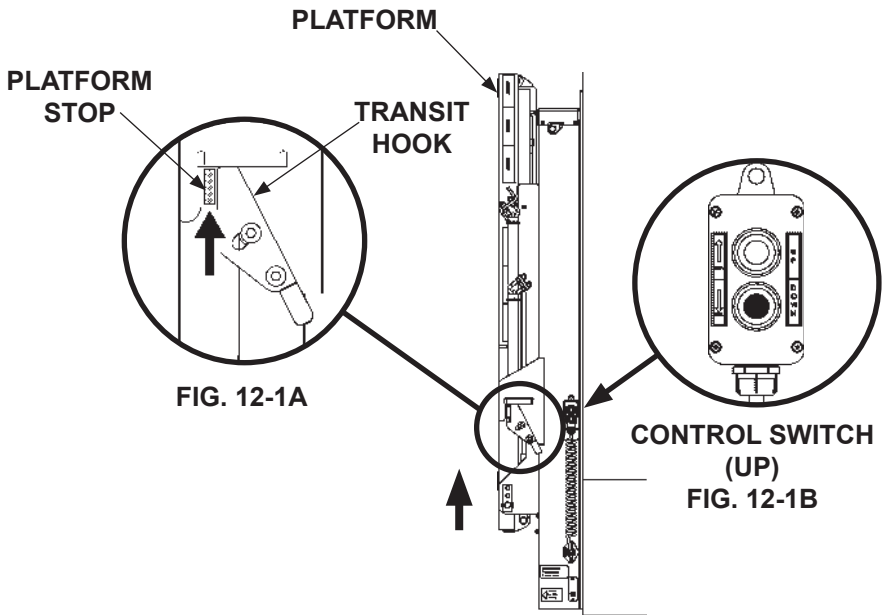

RAISING PLATFORM STOP OFF TRANSIT HOOK
FIG. 12-1

2. Rotate transit hook away from platform stop (FIG. 13-1A). Push control switch DOWN button (FIG. 13-1B) to lower the platform until platform stop clears transit hook and arrow decals align on column and runner (FIGS. 13-1 and 13-1C).

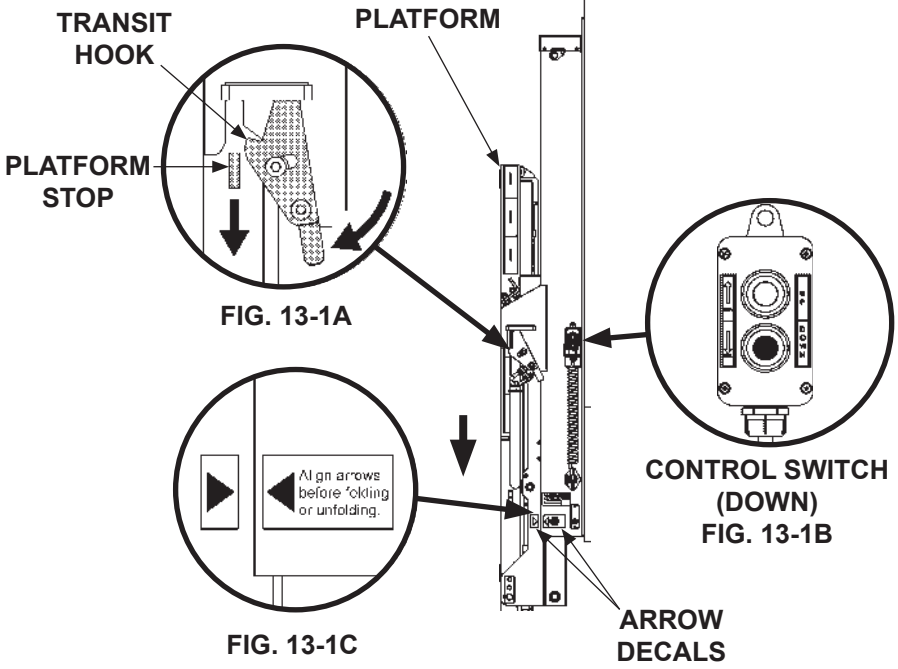

LOWERING PLATFORM TO ALIGN ARROWS
FIG. 13-1

UNFOLDING THE PLATFORM - Continued

3. Hold power closer button and control switch **DOWN** button (FIGS. 14-1A and 14-1B) at the same time to unfold platform (FIG. 14-1).

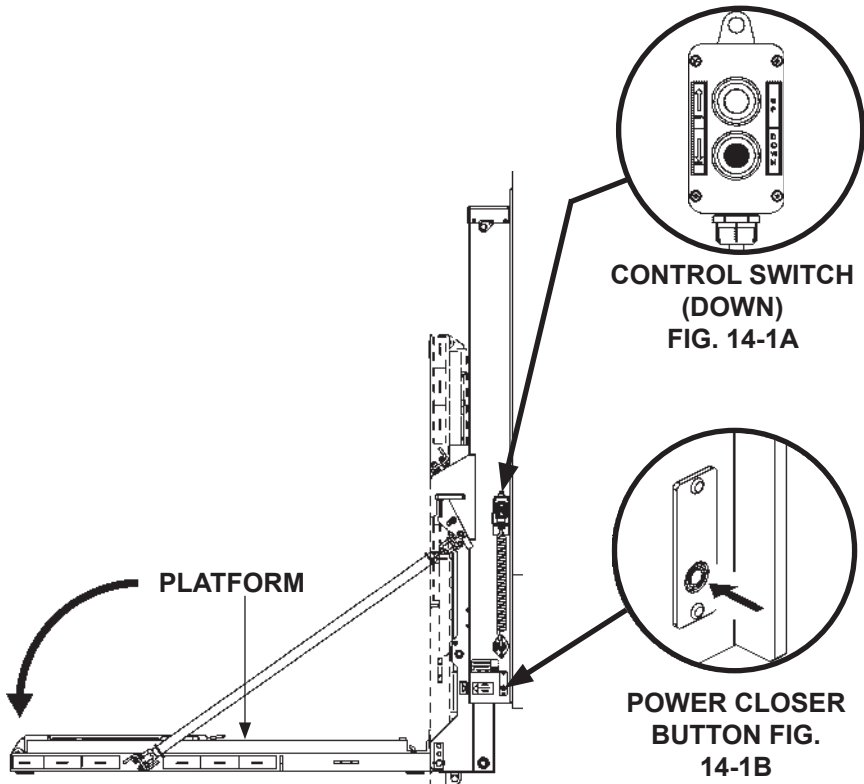

UNFOLDING PLATFORM
FIG. 14-1

4. Push latch in direction of arrow to unlock and unfold flipover (FIGS. 15-1 and 15-1A).

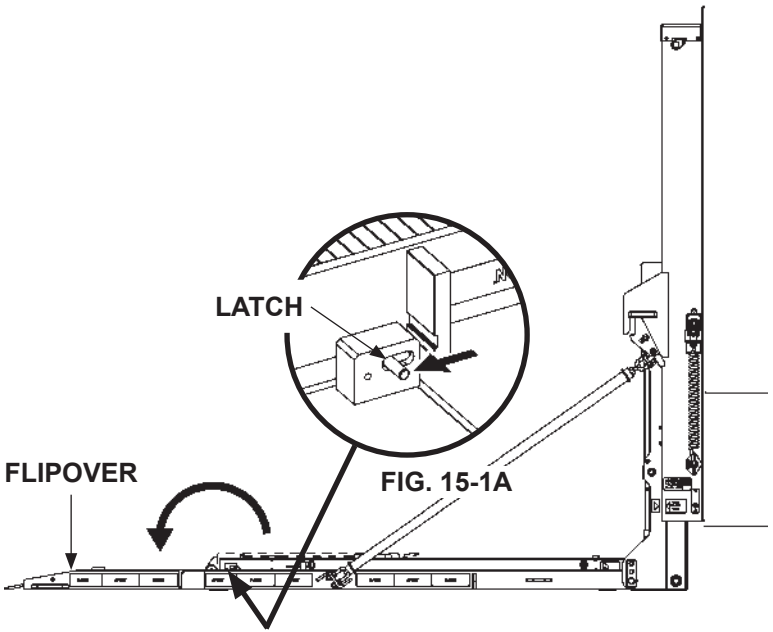

UNFOLDING FLIPOVER
FIG. 15-1

LOADING VEHICLE LOWERING THE PLATFORM

Press control switch **DOWN** button to lower platform (**FIG. 16-1A**). Release **DOWN** button when platform reaches the ground (**FIG. 16-1**).

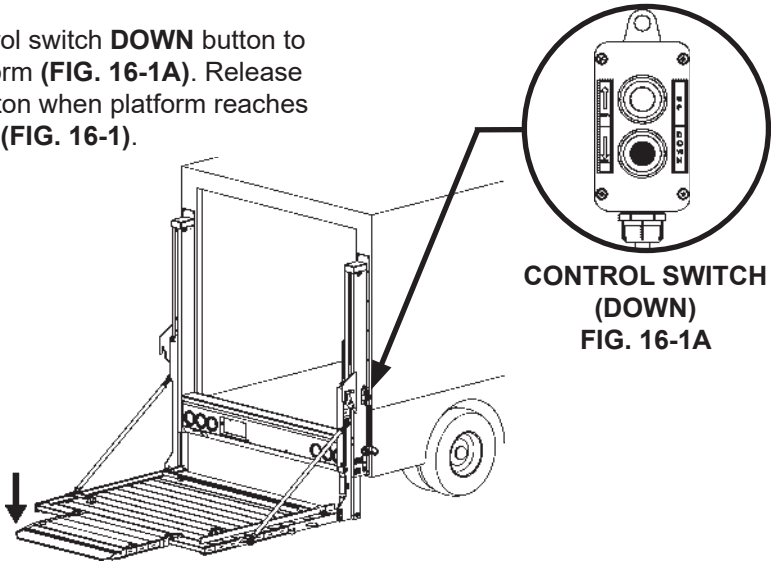

**CONTROL SWITCH
(DOWN)
FIG. 16-1A**

FIG. 16-1

POSITIONING LOAD

⚠ WARNING

A load should never extend past the edges of the platform. Do not place unstable loads on platform and do not allow load to exceed lifting capacity of Liftgate. If standing on platform, do not allow your feet to extend beyond inboard edge of platform.

1. For roll-off protection, push latch (**FIG. 16-2**) in direction of arrow and rotate the RH guide rail to the inboard position (**FIG. 16-2**). Repeat for rail on LH side of platform.

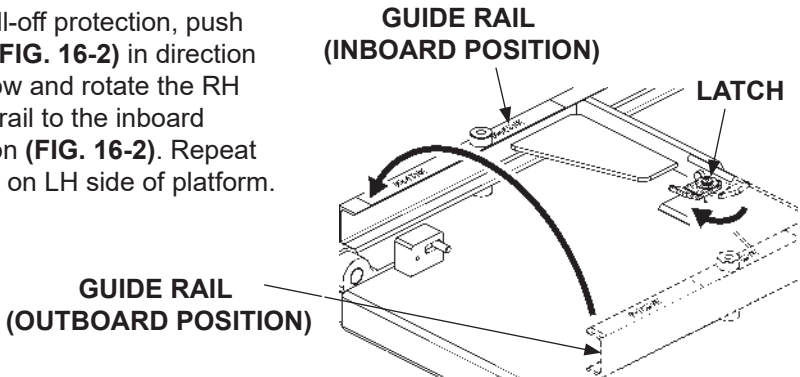

**ROTATING GUIDE RAIL TO INBOARD POSITION
(RH VIEW OF PLATFORM)**

FIG. 16-2

2. Using your foot, push the rear cart stop opener block to the open position (FIG. 17-1).

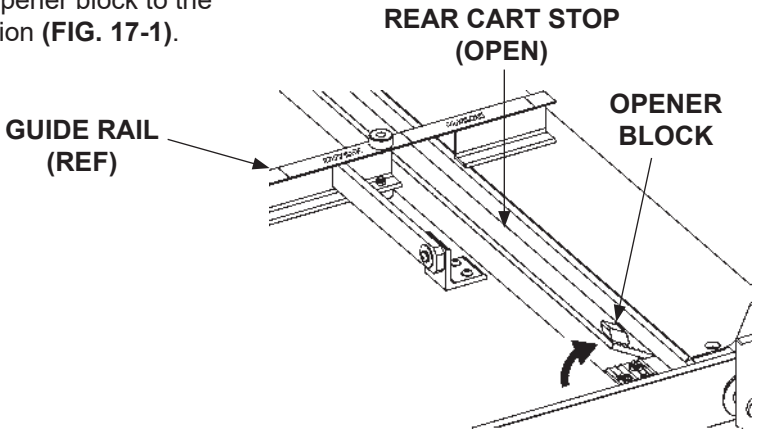

**OPENING REAR CART STOP
FIG. 17-1**

3. Place all loads against the rear cart stop, with heaviest part toward the truck body as shown in FIG. 17-2. Move loads across the ramp (FIG. 17-2) to the platform, but never rest or raise loads on the ramp. If standing on platform with the load, stand in the footprint area shown and comply with the preceding **WARNING**.

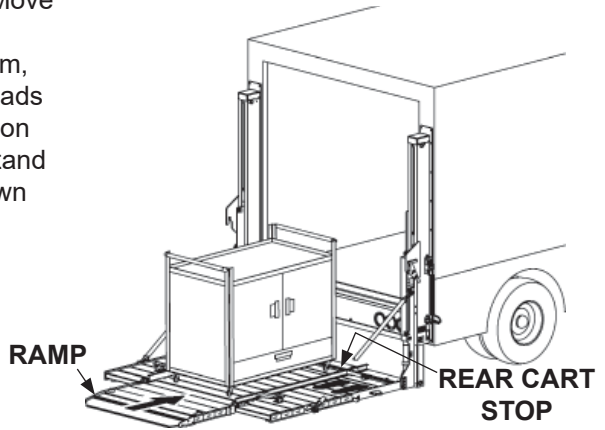

**LOADING PLATFORM AT GROUND LEVEL
FIG. 17-2**

LOADING VEHICLE - Continued

POSITIONING LOAD - Continued

4. To open front cart stop, push latch in direction shown in **FIG. 18-1**. Lift cart stop to open position (**FIG. 18-1**).

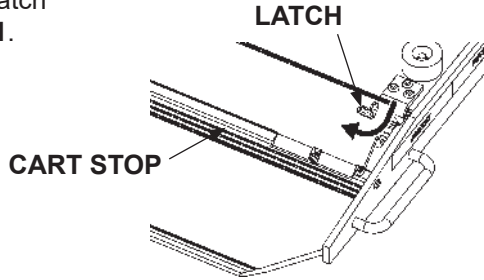

OPENING FRONT CART STOP
(RH VIEW OF FLIP OVER)
FIG. 18-1

RAISING & UNLOADING PLATFORM

⚠ CAUTION

A cart stop can trip you when stepping over it. To prevent possible injury, get on the platform before putting the cart stop in open position.

1. Press control switch **UP** button (**FIG. 18-2A**) to raise platform from ground level to bed height (**FIG. 18-2**). Release control switch button when platform reaches bed height (**FIG. 18-2**).

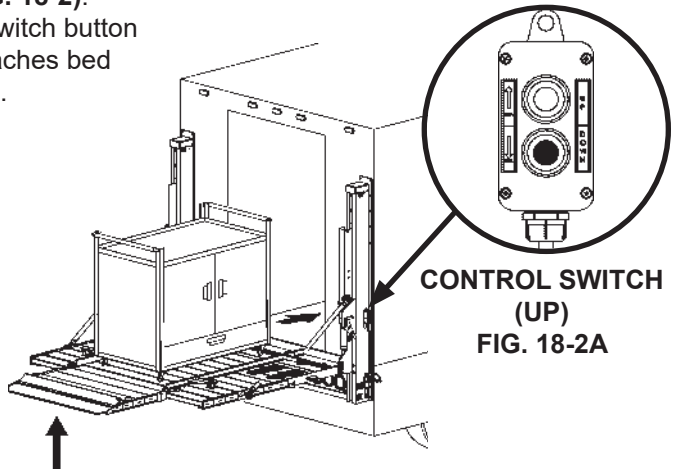

MOVING LOAD INTO VEHICLE
FIG. 18-2

- Using your foot, push the rear cart stop opener block to the closed position (**FIG. 19-1**).

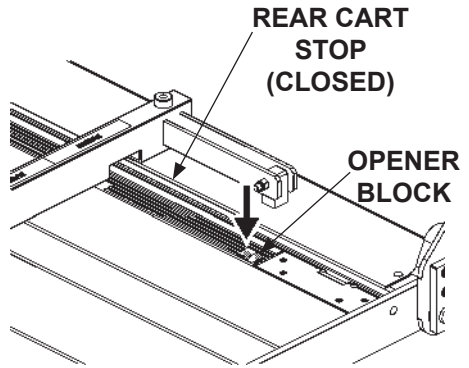

CLOSING REAR CART STOP
FIG. 19-1

- Carefully move the load into vehicle (**FIG. 18-2**).
- To close front cart stop, push latch in direction shown in **FIG. 19-2**. Step on cart stop and push down into locked position. (**FIG. 19-2**).

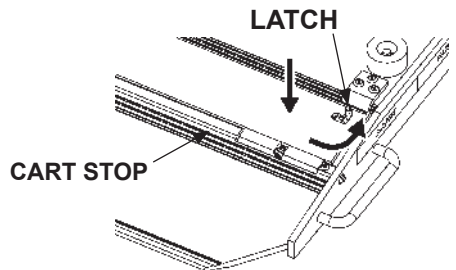

CLOSING FRONT CART STOPS
(RH VIEW OF FLIPOVER)
FIG. 19-2

- If there are more loads to put in vehicle, repeat the previous **LOADING VEHICLE** steps for each load. When loading is finished, use **STOWING PLATFORM** procedure in this manual.

UNLOADING VEHICLE POSITIONING LOAD

1. Press control switch **DOWN** button to lower platform (**FIG. 20-1A**). Release **DOWN** button when platform reaches the ground (**FIG. 20-1**).

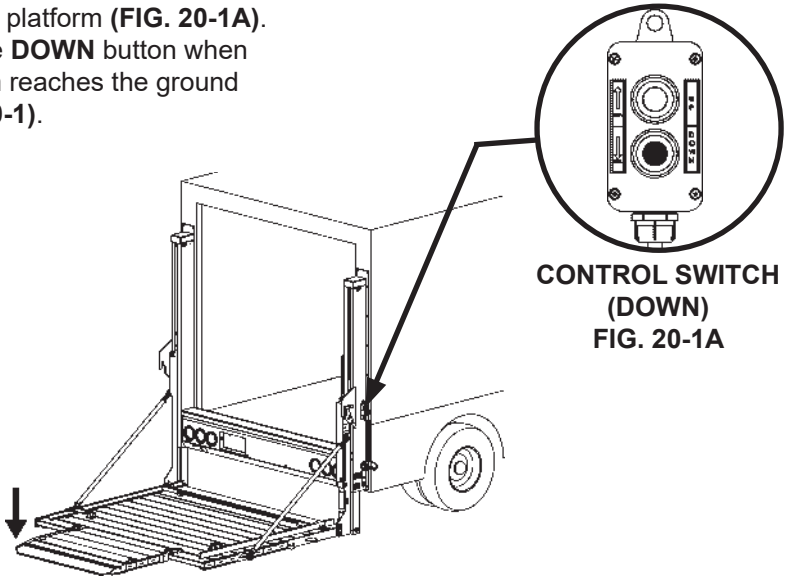

**LOWERING PLATFORM
FIG. 20-1**

2. To open front cart stop, push latch in direction shown in **FIG. 20-1**. Lift cart stop to open position (**FIG. 20-1**).

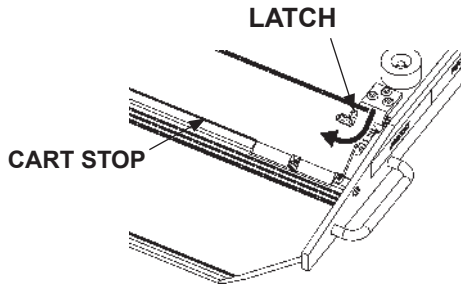

**OPENING FRONT CART STOP
(RH VIEW OF FLIP OVER)
FIG. 20-1**

3. For roll-off protection, push latch (**FIG. 21-1**) in direction of arrow and rotate the RH guide rail to the inboard position (**FIG. 21-1**). Repeat for rail on LH side of platform.

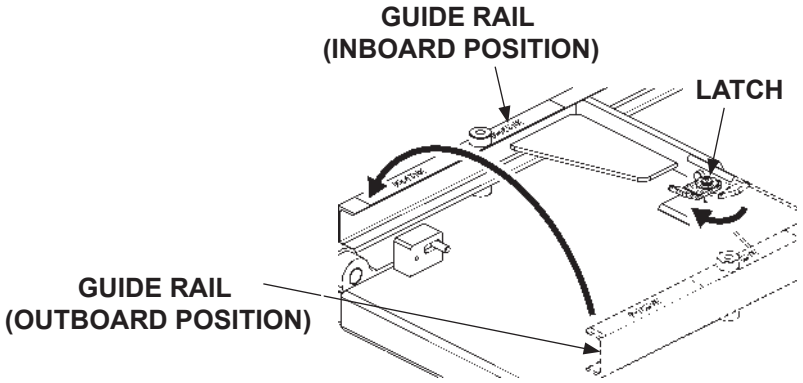

**ROTATING GUIDE RAIL TO INBOARD POSITION
(RH VIEW OF PLATFORM)
FIG. 21-1**

UNLOADING VEHICLE - Continued

POSITIONING LOAD - Continued

⚠ WARNING

A load should never extend past the edges of the platform. Do not place unstable loads on platform and do not allow load to exceed lifting capacity of Liftgate. If standing on platform, do not allow your feet to extend beyond inboard edge of platform.

⚠ WARNING

Pulling the load from vehicle to platform can result in a fall from platform and serious injury. When unloading vehicle, always push the load out on the platform.

4. Press control switch **UP** button to raise platform to bed height (**FIGS. 22-1 and 22-1A**).

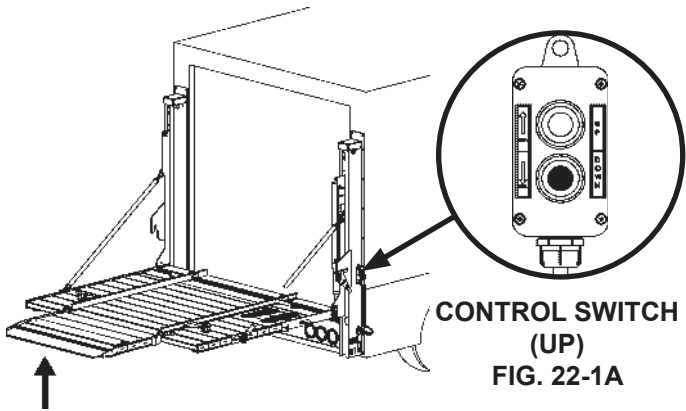

RAISING PLATFORM TO BED HEIGHT
FIG. 22-1

5. Load the platform at bed level (**FIG. 23-1**) as follows. Push load out of the vehicle to correct position on the platform. Place all loads as close as possible to the inboard edge of the platform with heaviest part toward the vehicle body as shown in **FIG. 23-1**. If standing on platform with the load, stand in the footprint area shown and comply with the **WARNING** on previous page.

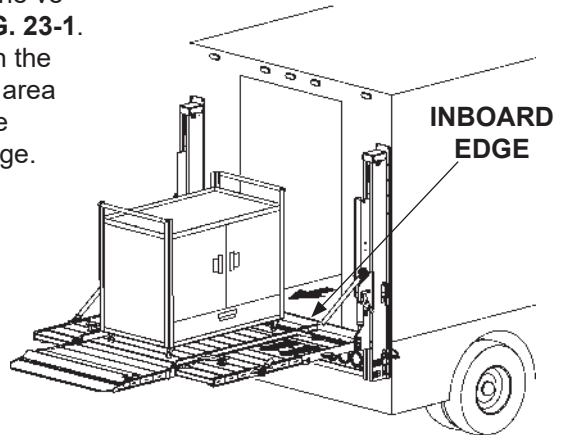

PUSHING LOAD ON PLATFORM
FIG. 23-1

6. Using your foot, push the rear cart stop opener block to the open position (**FIG. 23-2**).

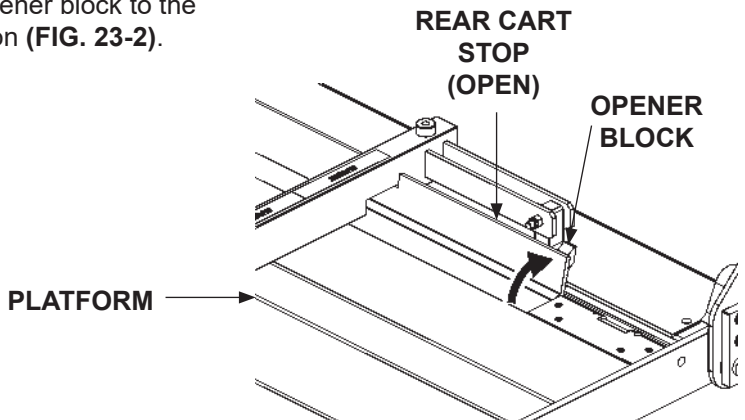

OPENING REAR CART STOP
FIG. 23-2

UNLOADING VEHICLE - Continued

LOWERING & UNLOADING PLATFORM

WARNING

Before lowering platform, make sure area surrounding platform is clear of people and objects. If standing on platform, do not allow your feet to extend beyond inboard edge of platform.

1. Press control switch **DOWN** button (**FIG. 24-1A**) to lower platform (**FIG. 24-1**). Release control switch button when platform reaches the ground (**FIG. 24-1**).

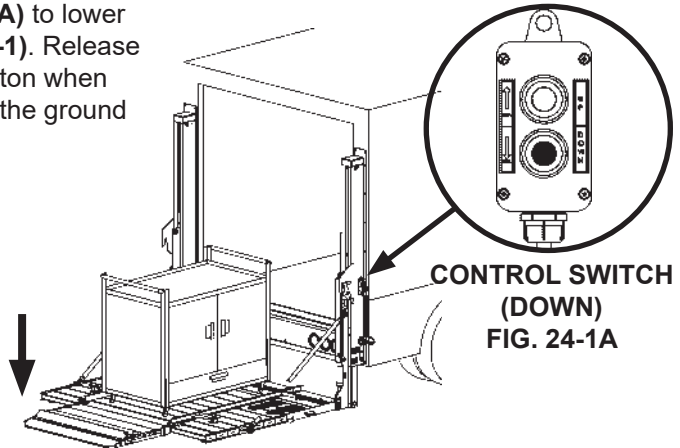

LOWERING PLATFORM TO GROUND LEVEL
FIG. 24-1

2. To close front cart stop, push latch in direction shown in **FIG. 24-2**. Step on cart stop and push down into locked position. (**FIG. 24-2**).

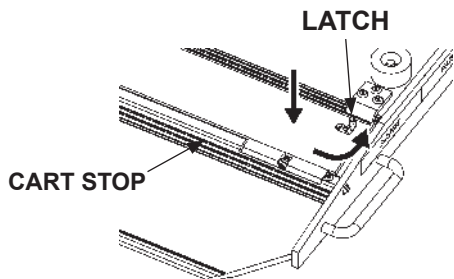

CLOSING FRONT CART STOPS
(RH VIEW OF FLIPOVER)
FIG. 24-2

3. Carefully move load off platform (**FIG. 25-1**) and then move it to a place where it will not become a hazard for people and other vehicles. If there is more to unload from vehicle, repeat the previous **UNLOADING VEHICLE** steps for each load. When unloading is finished, use **STOWING PLATFORM** procedure in this manual.

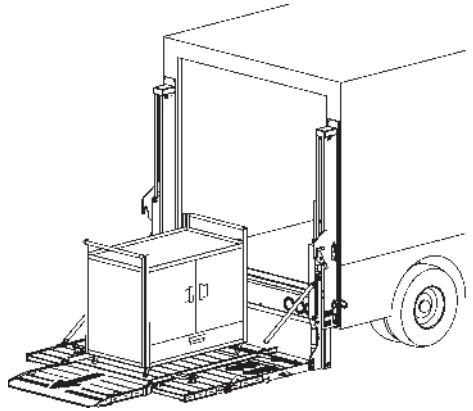

**MOVING LOAD OFF PLATFORM
FIG. 25-1**

STOWING PLATFORM

NOTE: Ensure platform is stowed under hydraulic pressure.

1. With platform on the ground (**FIG. 26-1**), push latch in direction of arrow and rotate the RH guide rail to the outboard position (**FIG. 26-1A**). Repeat for rail on LH side of platform.

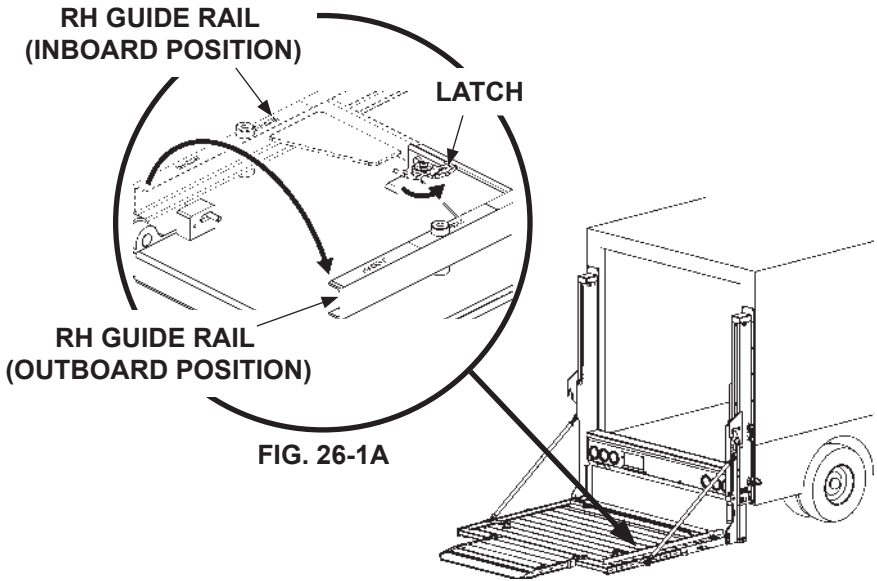

ROTATING GUIDE RAILS TO OUTBOARD POSITION
FIG. 26-1

2. Using your foot, push the rear cart stop opener block to the closed position (**FIG. 26-2**).

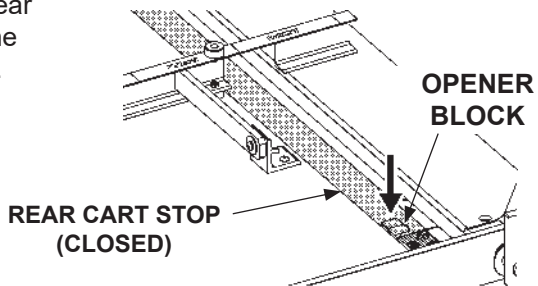

CLOSING REAR CART STOP
FIG. 26-2

3. Press control switch **UP** button to raise platform until arrow decals are aligned on runner and column (FIGS. 27-1 and 27-1A).

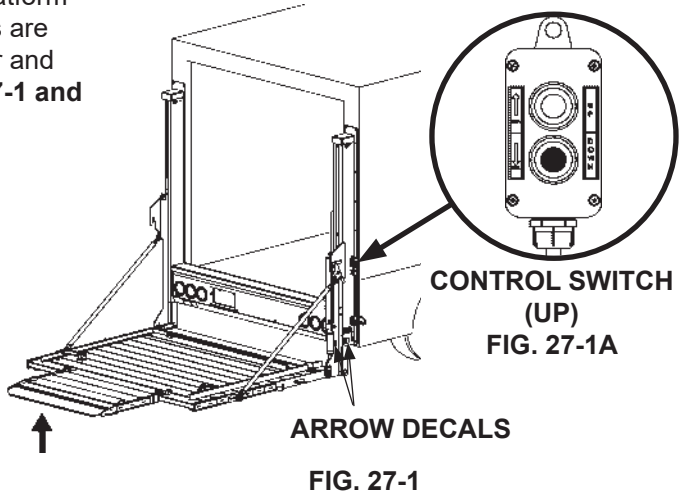

4. Fold and lock flipover. (FIGS. 27-2 and 27-2A).

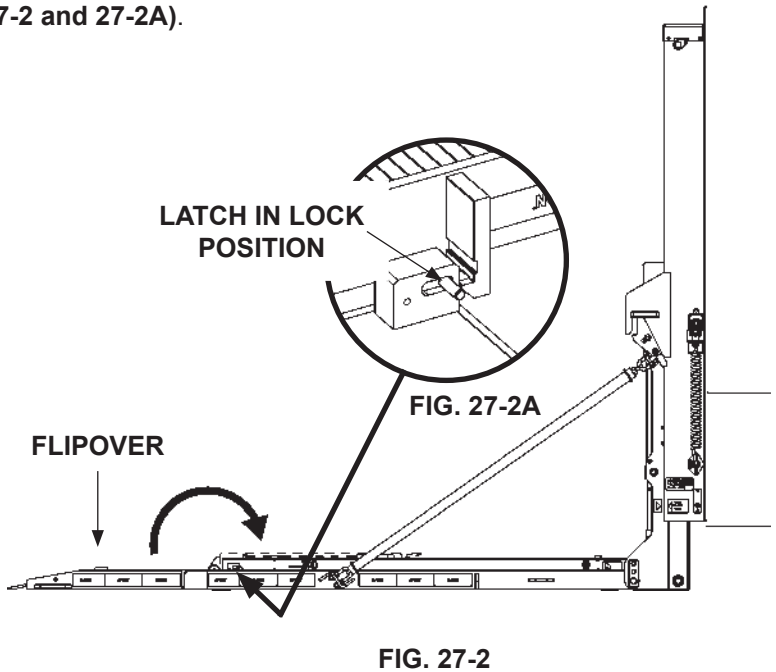

STOWING PLATFORM - Continued

CAUTION

Folding the platform with hydraulic closer requires 2 hands on the controls. This helps prevent injuries.

- Using one hand for control switch (FIG. 28-1A) and one hand for **POWER CLOSER** button (FIG. 28-1B), press **POWER CLOSER** button and **UP** button together until platform is folded (FIG. 28-1).

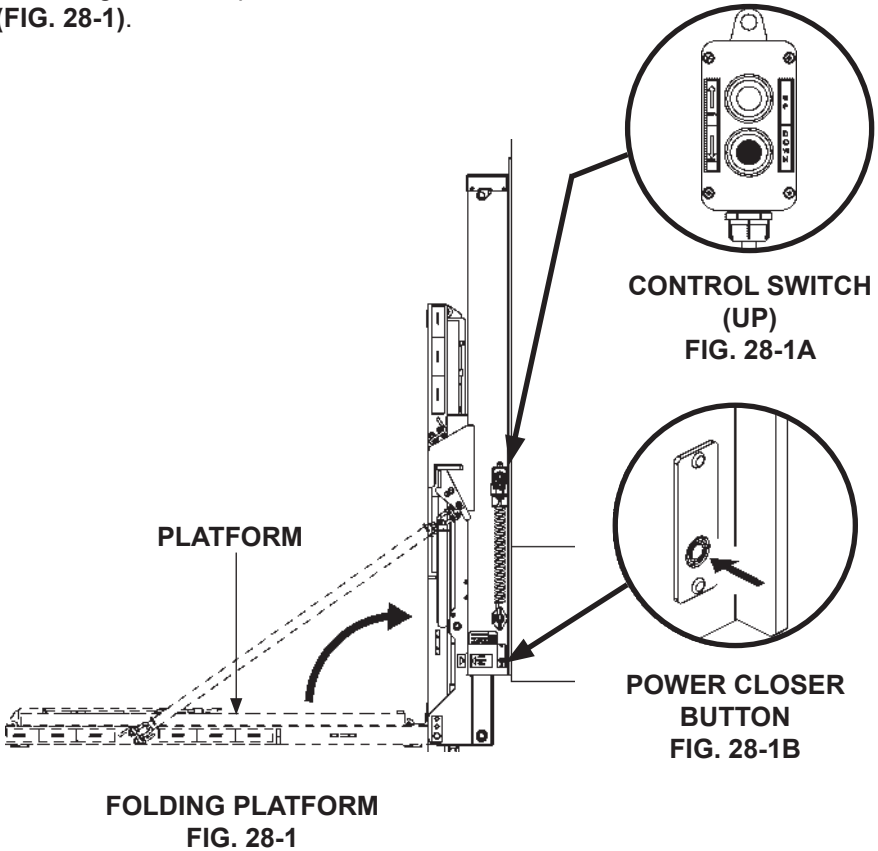

6. Press control switch **UP** button to raise platform (**FIGS. 29-1 and 29-1A**) until it is clear of transit hook (**FIG. 29-1B**). Final platform position is shown in **FIG. 29-1C**.

