

M-21-01
SEPTEMBER 2022

MAXON[®]

TOOL TRUCK

DMD-22

INSTALLATION MANUAL

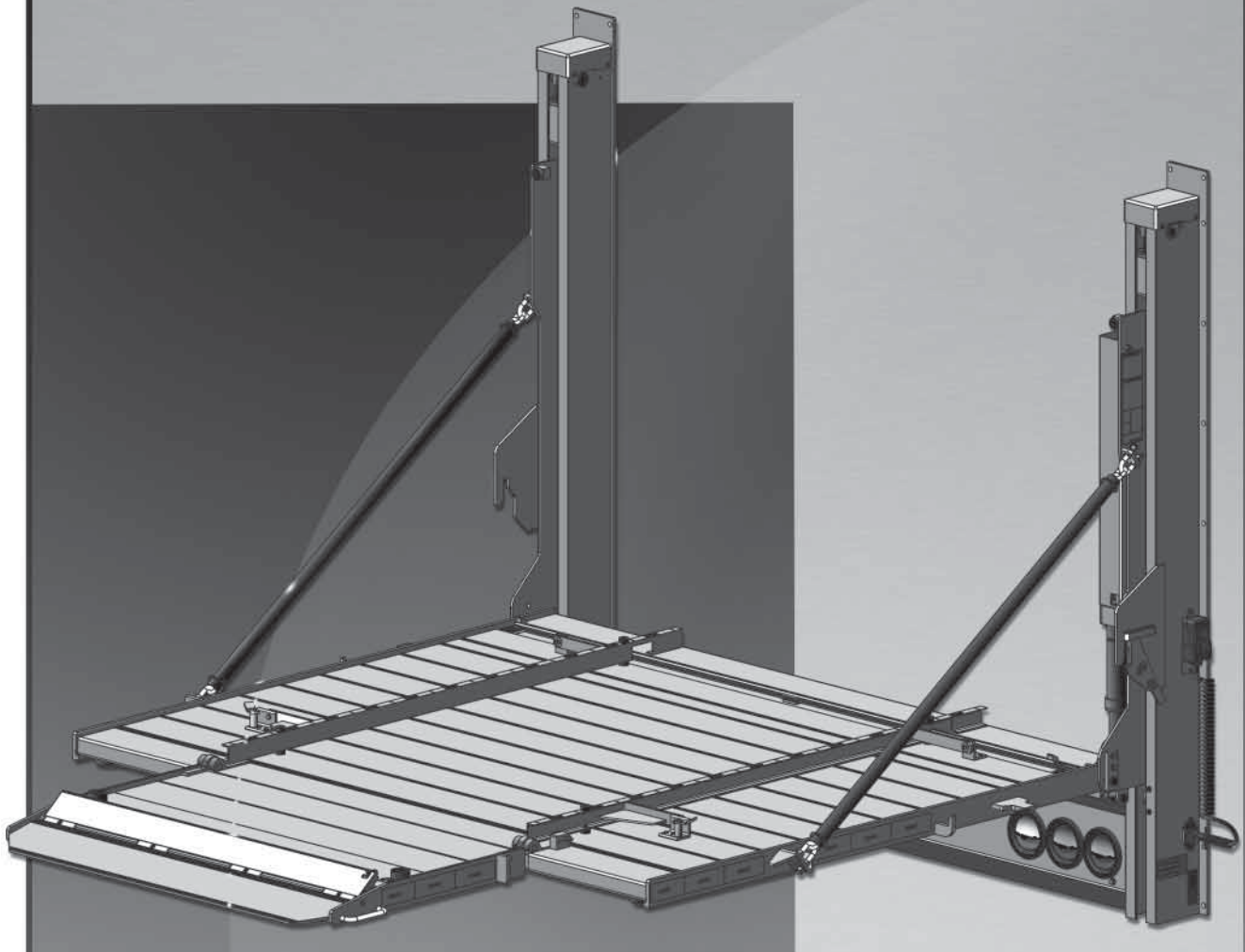
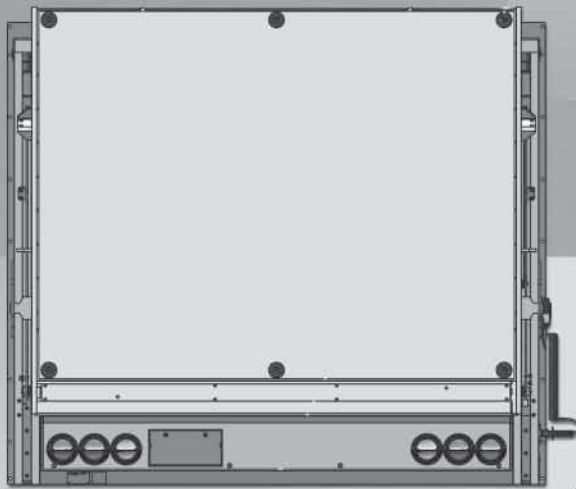

To find **maintenance & parts** information for your **Tool Truck DMD Liftgate**, go to www.maxonlift.com. Click the **PRODUCTS, RAILIFT & DMD** buttons. Open the **Maintenance Manual** in the **PRODUCT DOCUMENTATION** window. For parts, click on the **PARTS PORTAL, RAILIFT & DMD** buttons.

TABLE OF CONTENTS

WARNINGS	3
NOTICE	4
VEHICLE REQUIREMENTS	5
BODY STRENGTH.....	5
INSTALLED LIFTGATE	7
LIFTGATE INSTALLATION COMPONENTS	9
INSTALLATION & MANUALS KITS	10
STEP 1 - POSITION LIFTGATE	11
BOLTING LIFTGATE TO BODY	11
STEP 2 - RUN POWER & GROUND CABLES.....	12
STEP 3 - CONNECT POWER CABLE.....	13
STEP 4 - CONNECT GROUND CABLE	15
STEP 5 - PRESSURIZE HYDRAULIC SYSTEM	18
STEP 6 - CHECKING HYDRAULIC FLUID.....	19
STEP 7 - CONNECTING TAILLIGHTS.....	21
STEP 8 - REMOVE UPPER SUPPORT FIXTURE	22
DECALS	23
DECALS & PLATES	25
SYSTEM DIAGRAMS	26
PUMP MOTOR & VALVE OPERATION	26
HYDRAULIC SCHEMATIC.....	27
ELECTRICAL SCHEMATIC.....	28
ELECTRICAL SCHEMATIC (ABOVE BED MODEL).....	29
ELECTRICAL SCHEMATIC - JUMPER HARNESS ASSEMBLY	30
DMD ELECTRICAL VALUES & TORQUE VALUES.....	31
PRE-DELIVERY INSPECTION FORM	32

Comply with the following **WARNINGS** and **SAFETY INSTRUCTIONS** while installing Liftgates. See Operation Manual for operating safety requirements.

WARNING

Installing and maintaining a liftgate can expose you to chemicals, including lead, which are known to the State of California to cause cancer and birth defects or other reproductive harm. To minimize exposure, install and maintain liftgate in a well-ventilated area and wear **proper Personal protective equipment (PPE)**. For more information go to www.P65Warnings.ca.gov.

WARNING

- Do not stand, or allow obstructions, under the platform when lowering the Liftgate. **Be sure your feet are clear of the Liftgate.**
- **Keep fingers, hands, arms, legs, and feet clear of moving Liftgate parts (and platform edges) when operating the Liftgate.**
- **Correctly stow platform when not in use. Extended platforms could create a hazard for people and vehicles passing by.**
- **Make sure vehicle battery power is disconnected** while installing Liftgate. Connect vehicle battery power to the Liftgate only when installation is complete or as required in the installation instructions.
- If it is necessary to stand on the platform while operating the Liftgate, keep your feet and any objects clear of the inboard edge of the platform. Your feet or objects on the platform can become trapped between the platform and the Liftgate extension plate.
- Never perform unauthorized modifications on the Liftgate. Modifications may result in early failure of the Liftgate and may create hazards for Liftgate operators and maintainers.
- Recommended practices for welding on steel parts are contained in the current **AWS (American Welding Society) D1.1 Structural Welding Code - Steel**. Damage to Liftgate and/or vehicle, and personal injury can result from welds that are done incorrectly.
- Recommended practices for welding galvanized steel are contained in the current **AWS (American Welding Society) D19.0 Welding Zinc-Coated Steel**. Damage to Liftgate and/or vehicle, and personal injury can result from welds that are done incorrectly.

11921 Slauson Ave. Santa Fe Springs, CA. 90670 (800) 227-4116 FAX (888) 771-7713

MAXON[®]

SAFETY INSTRUCTIONS

- Read and understand the instructions in this **Installation Manual** before installing Liftgate.
- Before operating the Liftgate, read and understand the operating instructions in **Operation Manual**.
- Comply with all **WARNING** and instruction decals attached to the Liftgate.
- Keep decals clean and legible. If decals are illegible or missing, replace them. Free replacement decals are available from **Maxon Customer Service**.
- Consider the safety and location of bystanders and location of nearby objects when operating the Liftgate. Stand to one side of the platform while operating the Liftgate.
- Do not allow untrained persons to operate the Liftgate.
- Wear appropriate safety equipment such as protective eyeglasses, faceshield and clothing while performing maintenance on the Liftgate and handling the battery. Debris from drilling and contact with battery acid may injure unprotected eyes and skin.
- Be careful working by an automotive type battery. Make sure the work area is well ventilated and there are no flames or sparks near the battery. Never lay objects on the battery that can short the terminals together. If battery acid gets in your eyes, immediately seek first aid. If acid gets on your skin, immediately wash it off with soap and water.
- If an emergency situation arises (vehicle or Liftgate) while operating the Liftgate, release the control switch to stop the Liftgate.
- A correctly installed Liftgate operates smoothly and reasonably quiet. The only noticeable noise during operation comes from the power unit while the platform is raised and lowered. Listen for scraping, grating and binding noises and correct the problem before continuing to operate Liftgate.

NOTICE

- Maxon Lift is responsible for the instructions to correctly install **MAXON** Liftgates on trucks only.
- Liftgate installers, not Maxon Lift, are responsible for reviewing and complying with all applicable Federal, State, and Local regulations pertaining to the truck.

VEHICLE REQUIREMENTS

NOTE: Installer is responsible for ensuring vehicle meets Federal, State, and Local standards and regulations.

BODY STRENGTH

⚠ WARNING

Consult truck body manufacturer for truck body strength data. Make sure the forces created by the Liftgate are within the limits prescribed by the truck body manufacturer.

NOTE: Maximum Operating Bed Height (**Unloaded**) for body varies depending on platform. Refer to **TABLE 5-1**. Minimum Bed Height is **30" (Loaded)**. Do not install this Liftgate on vehicle bodies equipped with swing open doors.

The DMD is a body-mounted Liftgate that puts forces on the side walls of truck bodies (**FIG. 5-1**). For correct installation, truck bodies must be strong enough to withstand the tension, compression and shear forces shown in **FIG. 5-1**. Use **TABLE 5-1** to determine the forces that apply to your Liftgate.

X= Tension on each sidewall

Y= Compression on each sidewall

Z= Shear on each sidewall

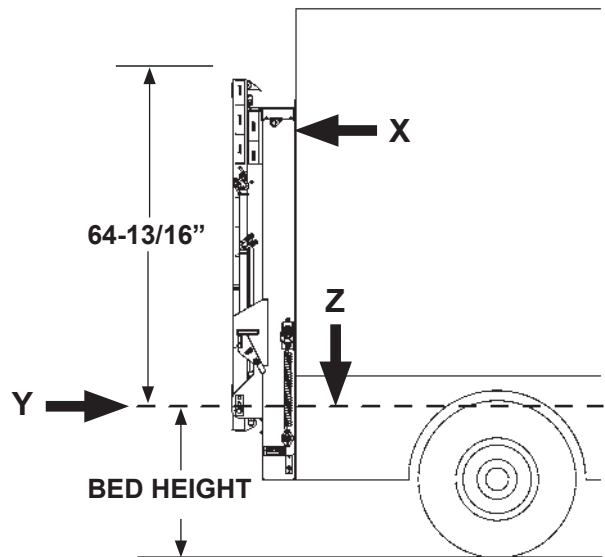

FIG. 5-1

DMD-22 FORCES		99" WIDE		102" WIDE	
MODEL CAPACITY	P/F SIZE	(X) (Y) LB	(Z) LB	(X) (Y) LB	(Z) LB
2200 LB	72"	1103	3098	1117	3136

TABLE 5-1

11921 Slauson Ave. Santa Fe Springs, CA. 90670 (800) 227-4116 FAX (888) 771-7713

MAXON

VEHICLE REQUIREMENTS - Continued

NOTE: Dimensions are provided as reference for fitting Liftgate to body.

NOTE: Make sure vehicle is parked on level ground while preparing vehicle and installing Liftgate.

1. Check for correct clearances (**FIGS. 6-1 and 6-2**) on vehicle to prevent interference between vehicle and Liftgate. Refer to **FIG. 6-1** for a standard installation. See **FIG. 6-2 and TABLE 6-1** for above bed options.

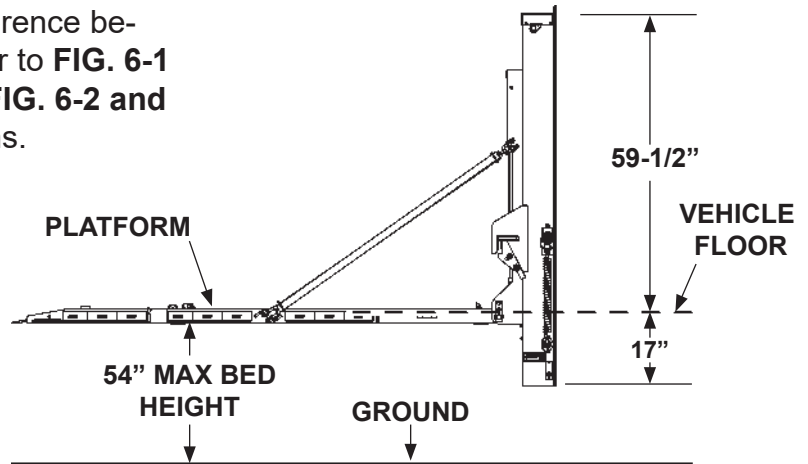

**STANDARD DMD
FIG. 6-1**

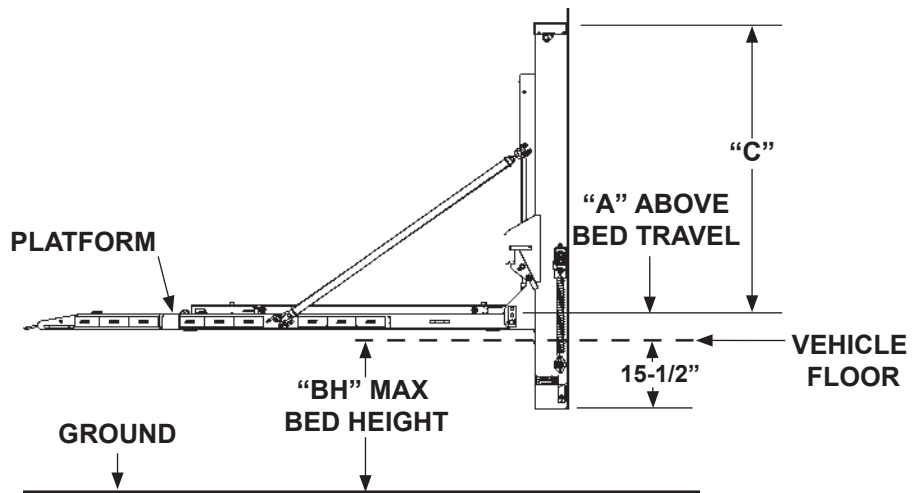

**DMD ABOVE BED OPTIONS
FIG. 6-2**

ABOVE BED TRAVEL "A"	1-1/4" (102" PLATFORM)	3-1/2" (99" PLATFORM)
MAX BED HEIGHT "BH"	52-3/4"	50-1/2"
COLUMN HEIGHT ABOVE BED "C"	59-1/2"	59-1/2"

**DMD ABOVE BED OPTIONS
TABLE 6-1**

VEHICLE REQUIREMENTS - Continued INSTALLED LIFTGATE

NOTE: If Liftgate columns exceed a 91 degree angle from level ground when installed on body, or if columns cannot be mounted flush against rear of vehicle, a steel filler may be used to bridge gap between vehicle body and Liftgate columns. Make sure the added materials and welds meet the **BODY STRENGTH** requirements shown on the previous pages.

1. With the vehicle parked on level ground, the columns of the DMD must be perpendicular to the ground (vertical) for the Liftgate to operate correctly (FIG. 7-1).

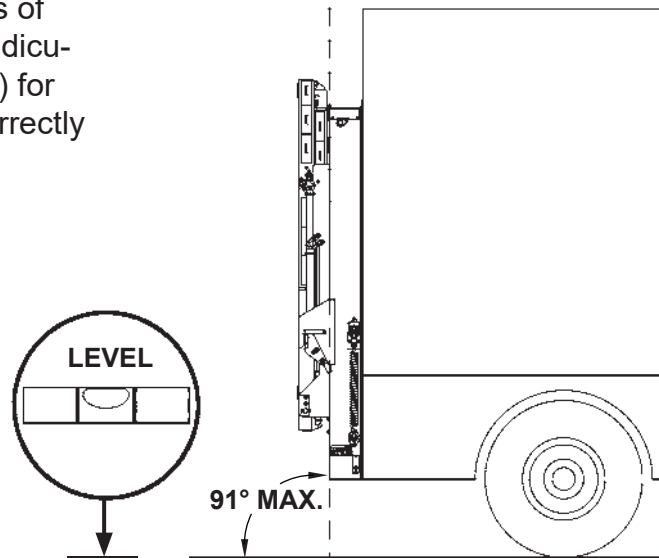

LIFTGATE INSTALLED ON TRUCK BODY
(COLUMNS SHOWN PERPENDICULAR TO LEVEL GROUND)
FIG. 7-1

VEHICLE REQUIREMENTS - Continued

2. With Liftgate centered on vehicle body, each column should fit on the corner posts of vehicle body with little or no offset (**FIG. 8-1**). Some offset from corner posts is allowed on the inboard side of the columns. Liftgate in stow position extends behind vehicle body as shown in **FIG. 8-1A**.

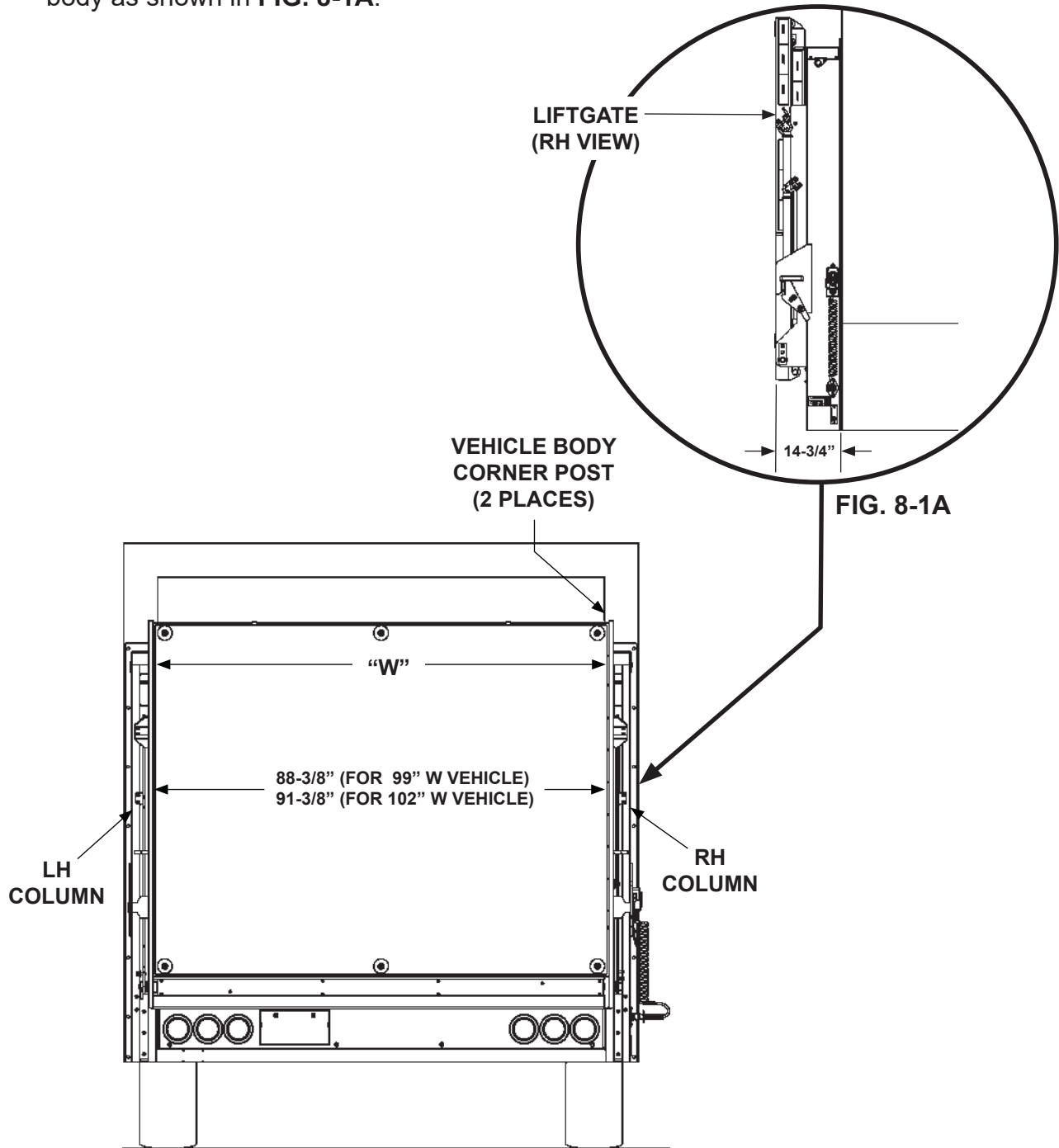

LIFTGATE COLUMNS FITTED TO BODY CORNER POSTS WITH LITTLE OR NO OFFSET
FIG. 8-1

LIFTGATE INSTALLATION COMPONENTS

NOTE: Make sure you have components and parts before you start installing Liftgate. Compare parts in the part box and each kit box with packing list enclosed in each box. If parts and components are missing or incorrect, call:

Maxon Customer Service
Call (800) 227-4116 or
Send e-mail to cservice@maxonlift.com

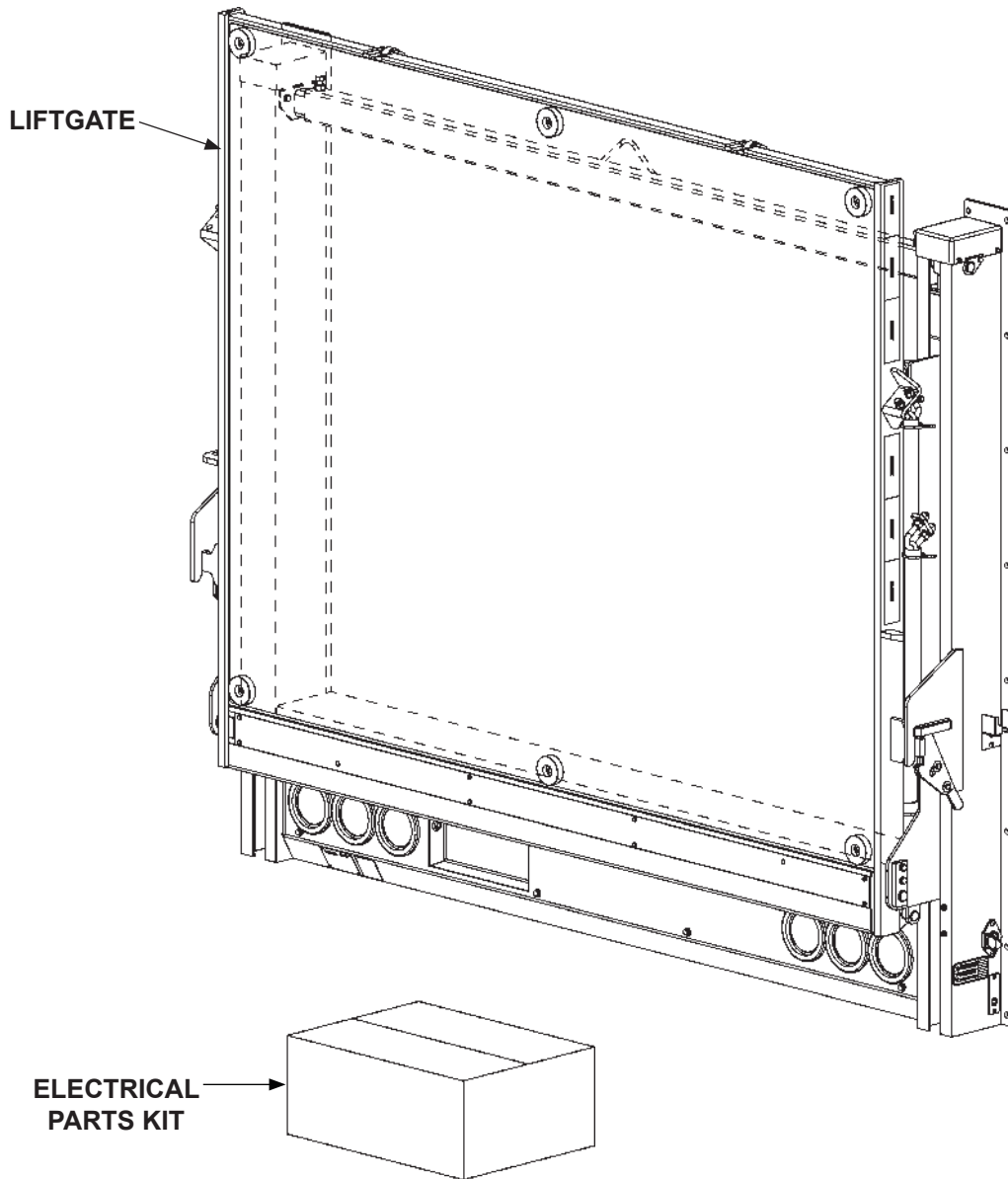

TOOL TRUCK DMD & PARTS KIT
FIG. 9-1

INSTALLATION & MANUALS KITS

To find **maintenance & parts** information for your **DMD Liftgate**, go to **www.maxonlift.com**. Click the **PRODUCTS, RAILIFT & DMD** buttons. Open the **Maintenance Manual** in the **PRODUCT DOCUMENTATION** window. For parts, click on the **PARTS PORTAL, RAILIFT & DMD** buttons.

ITEM	NOMENCLATURE OR DESCRIPTION	QTY	PART NUMBER
REF	DMD ELECTRICAL PARTS KIT	1	298882-11-100
1	HEAT SHRINK TUBING, 3/4" X 1-1/4" LG.	1	253316-04
2	HEAT SHRINK TUBING, 1" X 1-1/2" LG.	2	907169-01
3	STARTER SOLENOID, 12VDC	1	297271-01
4	HEX BOLT, 1/4"-20 X 1" LG.	2	903107-03
5	COPPER LUG, 2 GA, 5/16"	2	906497-02
6	CABLE ASSEMBLY, 2 GA, RED, 3/8", 1/4" RING, 24" LG.	1	212675-24
7	CABLE ASSEMBLY, 2 GA, RED, 1/4" RING, 35' LG.	1	212676-35
8	CABLE ASSEMBLY, 2 GA, BLACK, 3/8" RING, 35' LG.	1	212677-35
9	HEX HEAD NUT, 1/4"-20	2	903107-3
10	FLAT WASHER, 1/4"	2	903412-01
11	LOCK WASHER, 1/2" O.D. X 1/4" I.D.	2	902019-3
12	SPRING CLIP	8	050079
13	CIRCUIT BREAKER, 150 AMP	1	907207-02
14	2-BUTTON CONTROL PENDANT, GRAVITY DOWN	1	212516-01

TABLE 10-1

ITEM	NOMENCLATURE OR DESCRIPTION	QTY	PART NUMBER
REF	DMD MANUALS KIT	1	298884-11
1	INSTALLATION MANUAL	1	M-21-01
2	OPERATION MANUAL	1	M-21-02
3	DECAL, MAXON 24/7 SUPPORT	1	298634-01

TABLE 10-2

STEP 1 - POSITION LIFTGATE BOLTING LIFTGATE TO BODY

1. Use correct jig to drill holes in vehicle body.
2. Hoist liftgate by the installation support in position on the back of vehicle body (**FIG.11-1**). Next, align holes in the mounting flanges on the columns with bolt holes drilled in the corner posts on the vehicle body (**FIG.11-1**). Then, bolt Liftgate to vehicle body with mounting bolts provided by vehicle OEM (**FIG. 11-1**). Torque mounting bolts to OEM specifications.

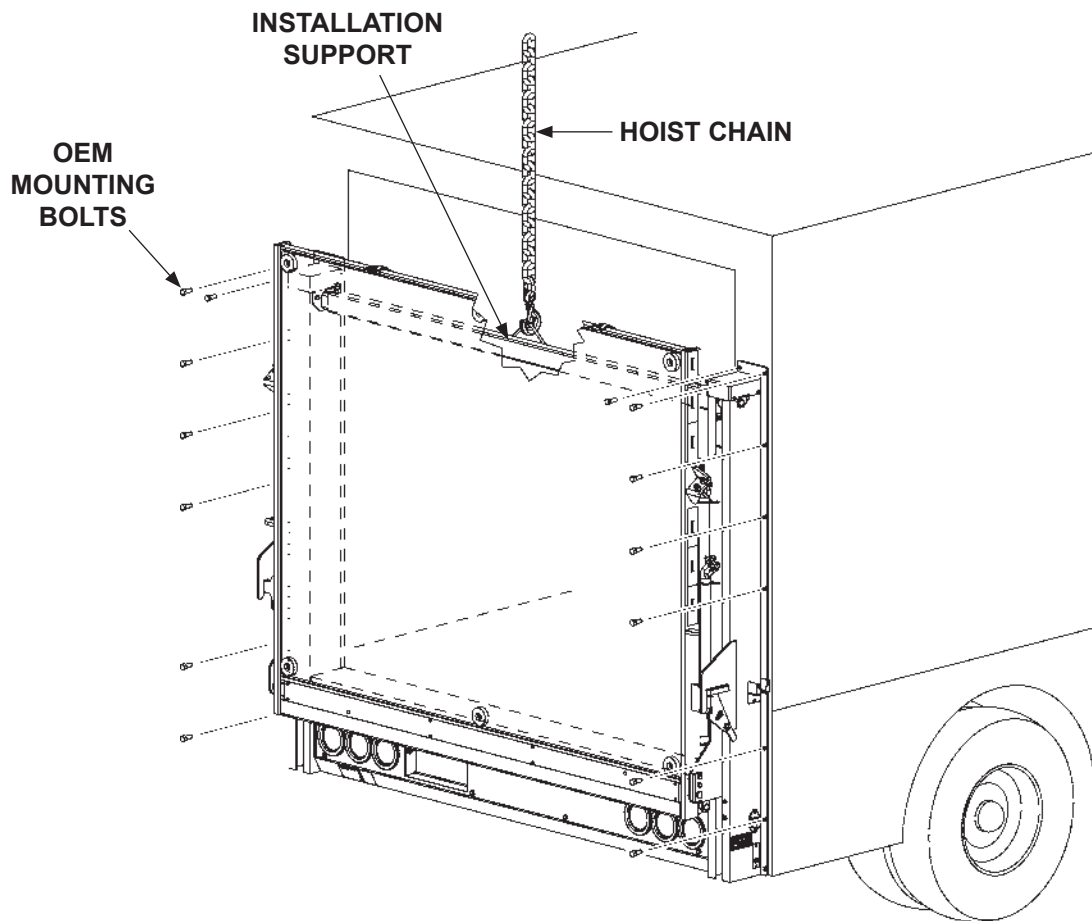

POSITIONING LIFTGATE & BOLTING ON VEHICLE BODY
FIG. 11-1

STEP 2 - RUN POWER & GROUND CABLES

⚠ CAUTION

Never route an energized wire. Make sure the vehicle battery is disconnected. Always route electrical wires clear of moving parts, brake lines, sharp edges and exhaust systems. Keep power and ground wires separated. Avoid making sharp bends in wiring. Attach securely. If drilling is necessary, first check behind the drilling surface to prevent damage to any fuel lines, vent lines, brake lines or wires.

NOTE: Ensure the lug end of each cable is inserted in the battery box on vehicle, but not connected. The end of each cable must be long enough to reach the power (+) and ground (-) terminal connections in battery box and Liftgate power unit in main housing without straining the cable connections.

1. Run the 35" power (+) cable and ground (-) cable (Kit items) along vehicle frame from vehicle battery box to Liftgate at rear of vehicle. Place lug end of power cable nearest the vehicle battery. Clip (Kit item) power (+) cable and ground (-) cable to vehicle frame at intervals shown in **FIG. 12-1**. Keep enough length of each cable to reach positive (+) and negative (-) terminals without straining cables when connected. Use plastic ties (Kit items) where needed.
2. Connect power (+) cable to **AUX** stud on 150 amp circuit breaker (Kit item), and 24" power (+) cable (Kit item) to the **BAT** stud on circuit breaker.
3. Fasten 150 amp circuit breaker to battery box with two 1/4"-20 bolts and nuts, and 1/4" washers supplied with parts kit.

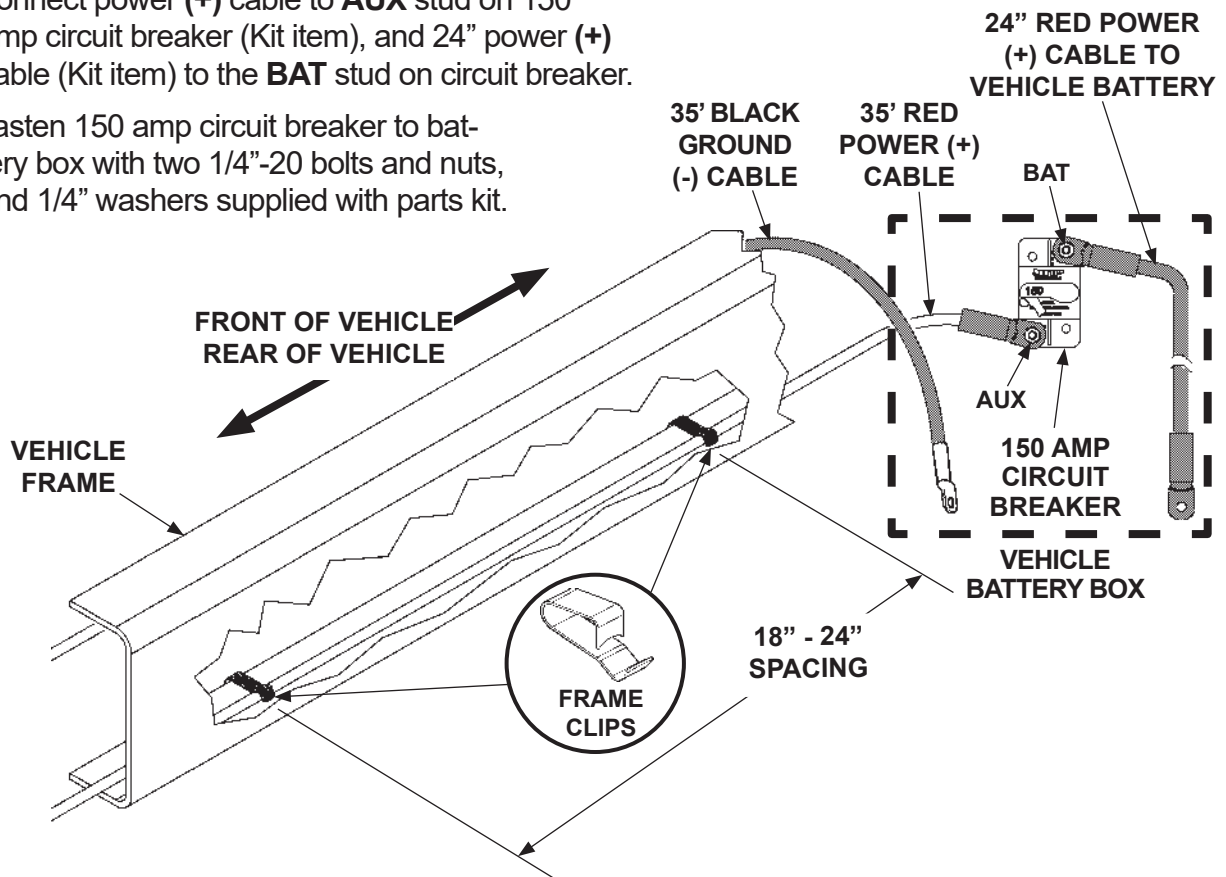

ROUTING POWER & GROUND CABLES FROM BATTERY BOX TO LIFTGATE
FIG. 12-1

STEP 3 - CONNECT POWER CABLE

1. Unbolt cover, disconnect taillight wiring harness, and remove cover from main housing (**FIG. 13-1**).

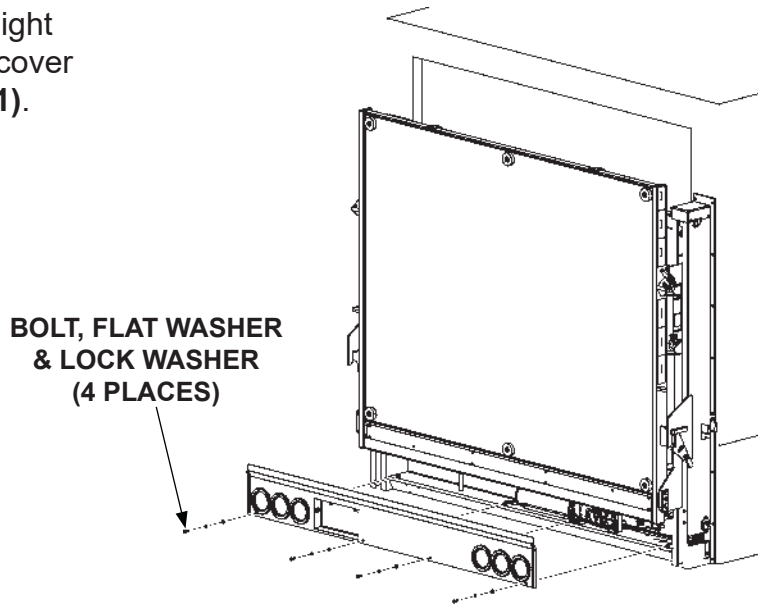

**COVER REMOVED FROM MAIN HOUSING
FIG. 13-1**

2. Run power (+) cable through grommet on bottom of main housing (**FIG. 13-2**). On the bare wire end of red power (+) cable, keep enough length to attach copper terminal lug (Kit item) and reach motor starter switch without putting tension on cable (after connection) (**FIGS. 13-1 and 13-2**). Measure (if needed), and then cut excess cable from bare wire end of cable. Put heat shrink tubing (Kit item) (**FIG. 13-2A**) on the end of the cable and leave room for terminal lug. Crimp and solder copper terminal lug on the power (+) cable and shrink the heat shrink tubing over the barrel-end of the lug (**FIG. 13-2B**).

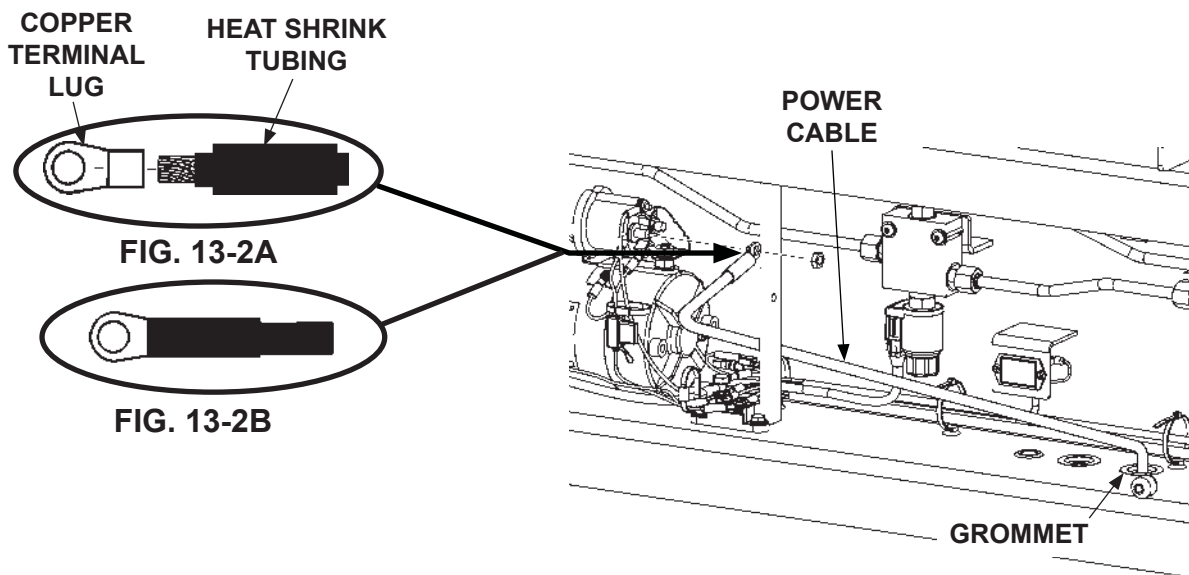

**INSTALLING LUG ON POWER CABLE
FIG. 13-2**

STEP 3 - CONNECT POWER CABLE - Continued

CAUTION

Do not over-tighten the terminal nuts on starter solenoid. For the load terminals, torque nuts to 30-35 lb-in max. Torque the nuts on #10-32 control terminals 10-15 lb-in.

NOTE: Do not remove flat washer from battery power terminal on starter switch.

3. Remove hex nut from battery power terminal on the starter switch (**FIG. 14-1**). Connect power cable to starter switch as shown in **FIG. 14-1**. Reinstall and tighten hex nut.

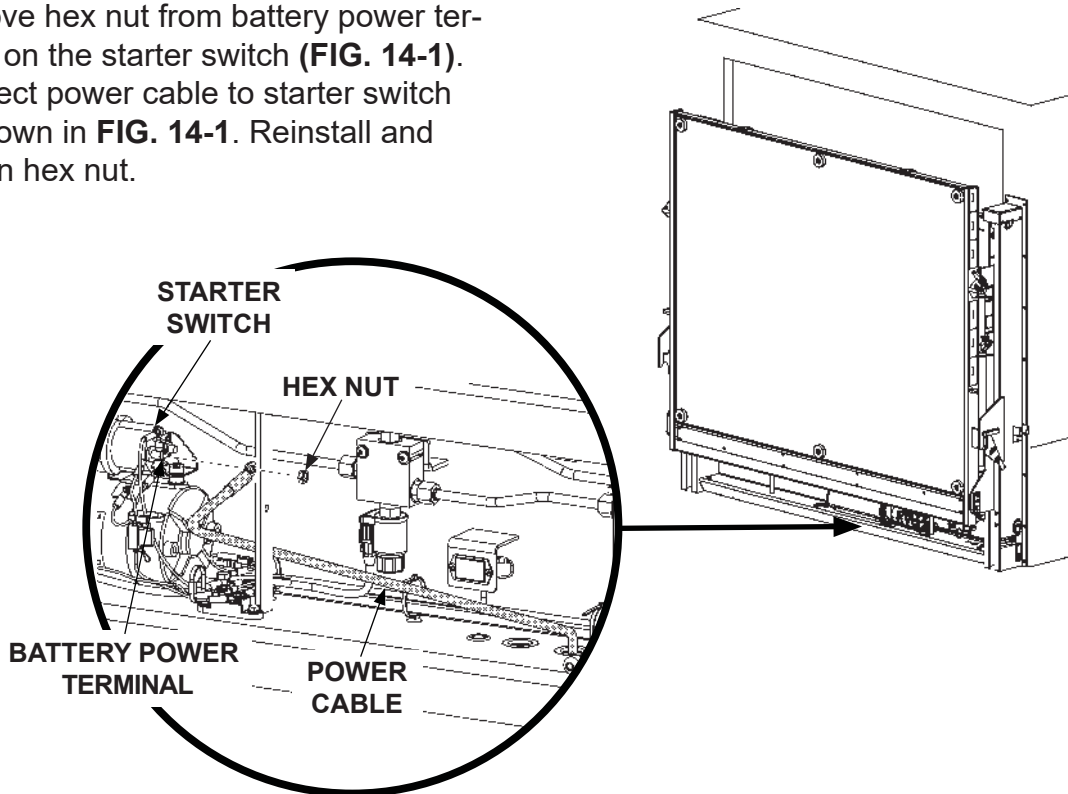

CONNECTING POWER CABLE TO STARTER SWITCH
FIG. 14-1

STEP 4 - CONNECT GROUND CABLE

NOTE: To ensure power unit is grounded correctly, connect black ground (-) cable (Kit item) to grounding point on pump manifold and common ground point on vehicle.

1. Run ground (-) cable through grommet on bottom of main housing (FIGS. 15-1 and 15-1A). On the bare wire end of ground (-) cable, keep enough length to attach copper terminal lug (Kit item) and reach grounding point on pump manifold without putting tension on cable (after connection) (FIG. 15-1A). Measure (if needed), and then cut excess cable from bare wire end of cable (FIG. 15-1B). Put heat shrink tubing (Kit item) on the end of the cable and leave room for terminal lug. Crimp and solder copper terminal lug on the ground (-) cable and shrink the heat shrink tubing over the barrel-end of the lug (FIG. 15-1C).

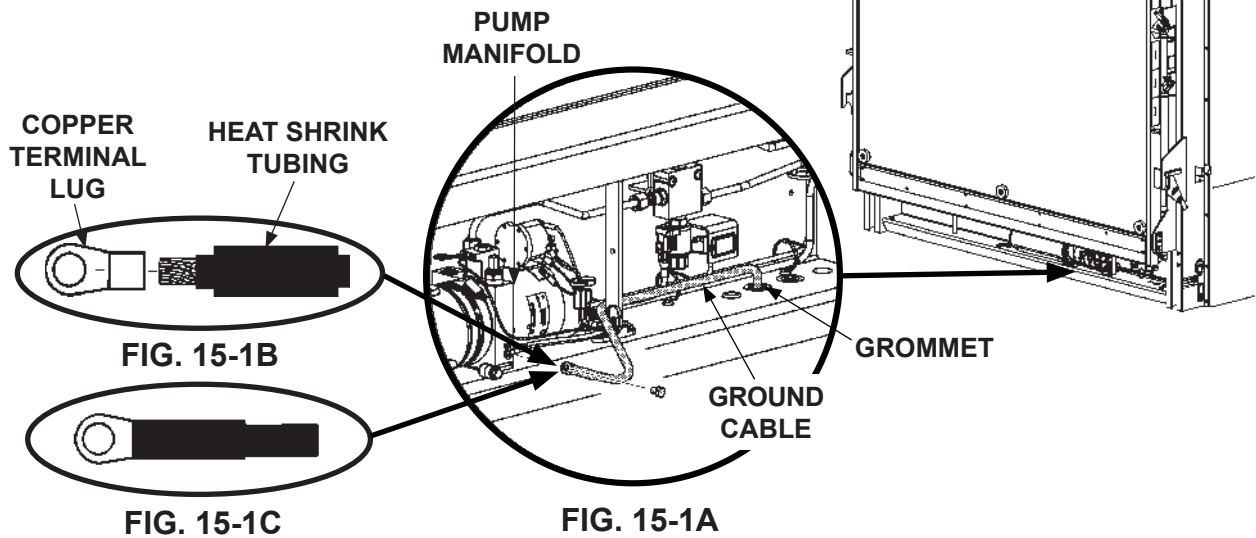

INSTALLING LUG ON GROUND CABLE
FIG. 15-1

STEP 4 - CONNECT GROUND CABLE - Continued

2. Remove hex bolt from grounding point on pump manifold (**FIG. 16-1**). Then, bolt lug on the ground cable to grounding point on manifold (**FIG. 16-1**). Torque bolt to **18-22 lb-ft**.

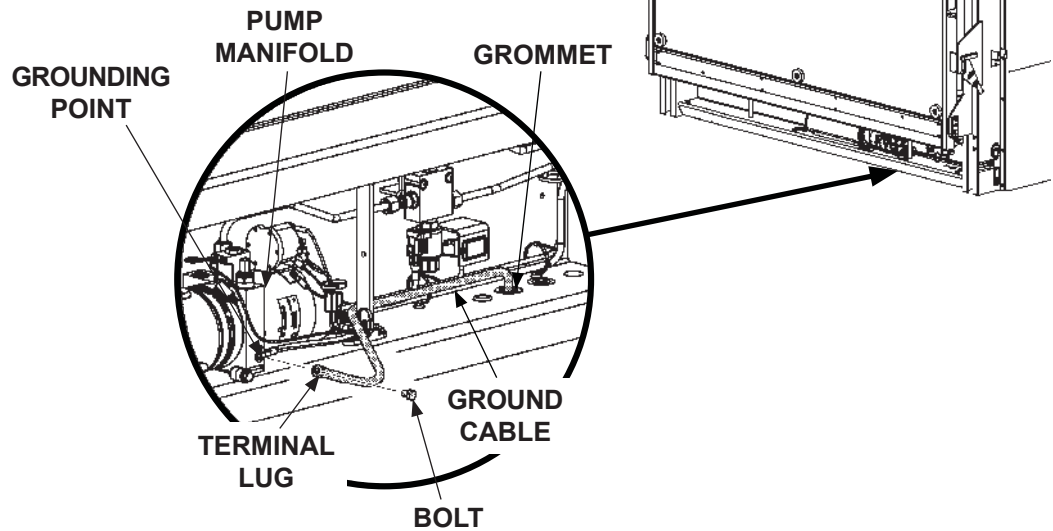

CONNECTING GROUND CABLE TO POWER UNIT
FIG. 16-1

STEP 5 - CONNECT POWER & GROUND CABLES TO VEHICLE BATTERIES

⚠ CAUTION

Make sure vehicle battery cables are disconnected before connecting liftgate power (+) and ground (-) cables to vehicle battery.

1. Connect power (+) cable with 150 amp circuit breaker for Liftgate to (+) terminal on OEM vehicle battery (FIG. 17-1).

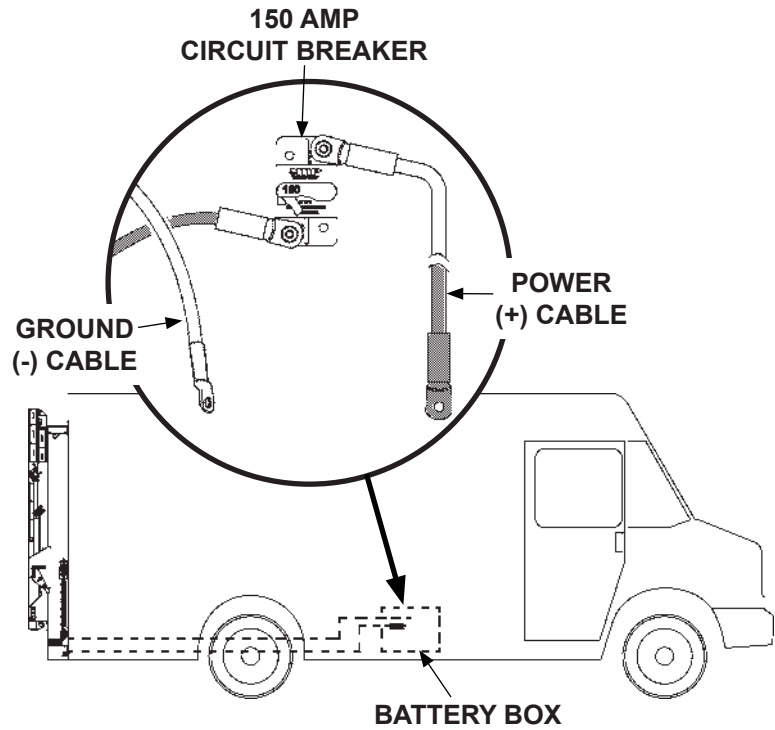

CONNECTING POWER & GROUND CABLES TO OEM VEHICLE BATTERY
FIG. 17-1

2. Connect ground (-) cable for Liftgate to (-) terminal on OEM vehicle battery (FIG. 17-1).
3. Reconnect OEM vehicle battery cables to OEM vehicle battery.

STEP 5 - PRESSURIZE HYDRAULIC SYSTEM

⚠ WARNING

To prevent injury and equipment damage, pressurize hydraulic system before removing lower support fixtures and operating Liftgate.

1. Get handheld control from parts kit. Next, open the electrical connector cover on the RH column of liftgate (**FIGS. 18-1 and 18-1A**). Place handheld control in holder and plug control cable in electrical connector (**FIG. 18-1A**).

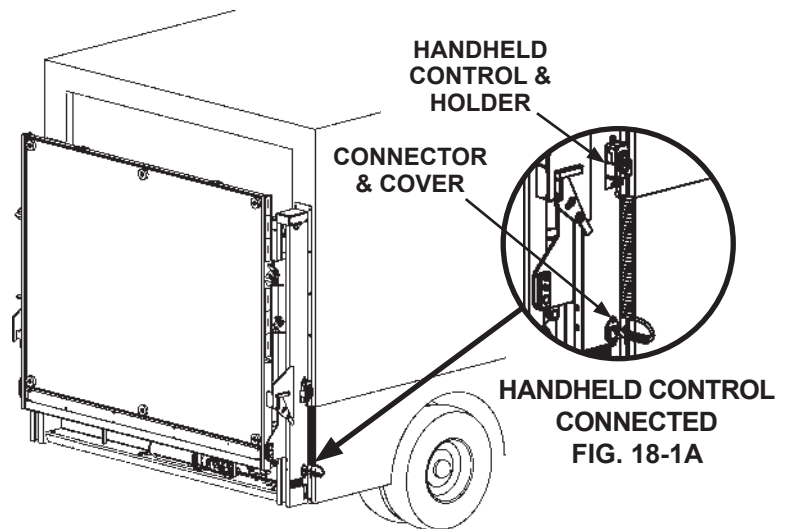

**CONNECTING HANDHELD CONTROL
FIG. 18-1**

2. Remove handheld control from holder (**FIGS. 18-1 and 18-1B**). To pressurize hydraulic system, press **UP** button for 5-10 seconds (**FIG. 18-2A**). Then, release the button (**FIG. 18-1B**).

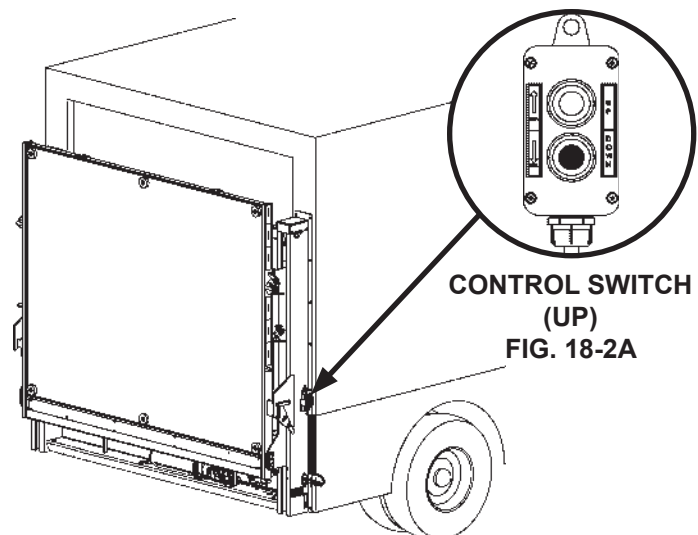

**USING CONTROL TO PRESSURIZE
HYDRAULIC SYSTEM
FIG. 18-2**

STEP 6 - CHECKING HYDRAULIC FLUID

CAUTION

Keep dirt, water and other contaminants from entering the hydraulic system. Before opening the hydraulic fluid reservoir filler cap, drain plug and hydraulic lines, clean up contaminants that can get in the openings. Also, protect the openings from accidental contamination.

Never mix synthetic fluids with conventional hydraulic fluids. Hydraulic system must be purged if the fluids are mixed.

NOTE: Liftgate is shipped with **Exxon Univis HVI-13** hydraulic fluid in the hydraulic cylinders. **Exxon Univis HVI-13** hydraulic fluid is recommended for operating temperatures of **-40 to +120° F**. Refer to decal in pump box. Under certain conditions, other brands and grades of oil may be used as substitutes for the recommended oil. See **TABLES 20-1** for recommended brands of **ISO 15** oil.

1. Unfold and lower platform to the ground (**FIG. 19-1**). Refer to **Operation Manual** for detailed operating instructions.
2. Check the hydraulic fluid level in reservoir as follows. With platform on the ground, level should be as shown in **FIG. 19-2**.

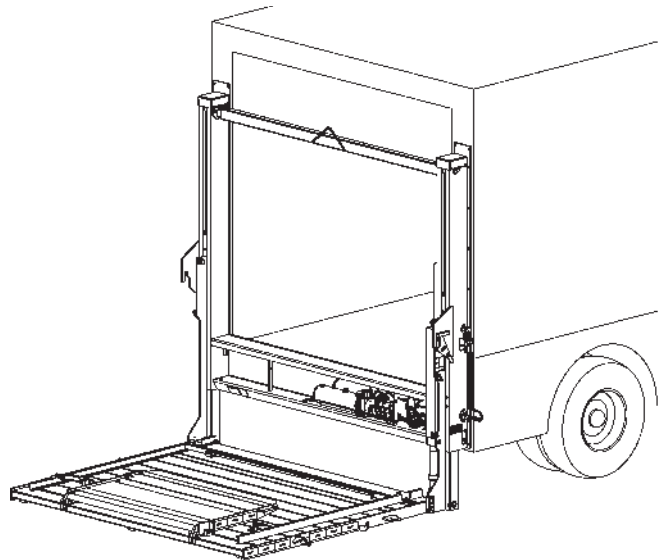

PLATFORM OPEN ON THE GROUND
GROUND FIG. 19-1

3. If needed, add fluid to the reservoir as follows. Remove filler cap (**FIG. 19-2**). Fill the reservoir with hydraulic fluid to level shown in **FIG. 19-2**. Reinstall filler cap.

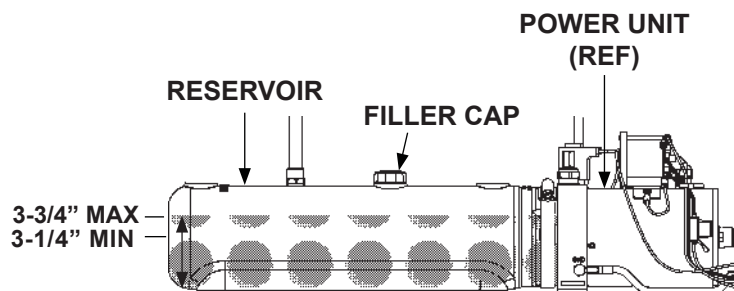

POWER UNIT FLUID LEVEL
(FIG. 19-2)

STEP 6 - CHECKING HYDRAULIC FLUID - Continued

ISO 15 OR MIL-H-5606 HYDRAULIC OIL	
RECOMMENDED BRANDS	PART NUMBER
CHEVRON	FLUID A, AW-MV-15
KENDALL	GLACIAL BLU
SHELL	TELLUS S2 VX 15
EXXONMOBIL	UNIVIS HVI-13
ROSEMEAD	THS FLUID 17111

TABLE 20-1

STEP 7 - CONNECTING TAILLIGHTS

1. Remove buttonhead screw, flat washer, lock nut and small cover plate from inside of the main housing at the bottom (**FIG. 21-1** and **FIG. 21-1A**). Save the cover and fasteners to reinstall.

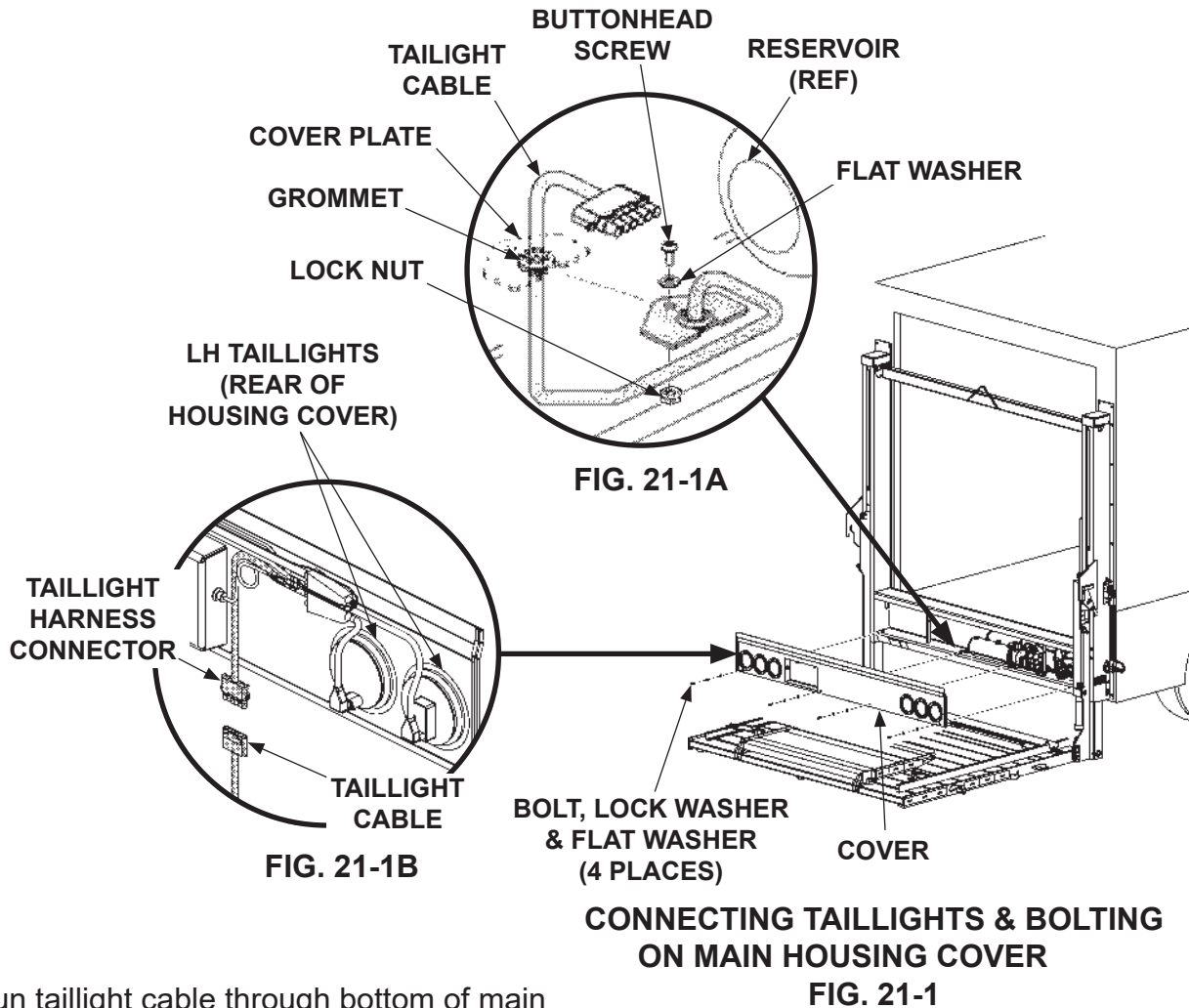

2. Run taillight cable through bottom of main housing (**FIGS. 21-1** and **21-1A**). Next, place split grommet and cover plate on the taillight cable (**FIG. 21-1A**). Then, use buttonhead screw, flat washer and lock nut to secure cover plate and cable to the main housing (**FIG. 21-1A**).

CAUTION

Main housing cover must be secured correctly to prevent it from becoming a hazard.

3. Connect the taillights harness to the taillight cable as shown in **FIG. 21-1B**. Then, bolt on the main housing cover as shown in **FIG. 21-1**. Torque the 5/16"-18 cover bolts from **10 to 14 lb-ft**.

STEP 8 - REMOVE UPPER SUPPORT FIXTURE

⚠ CAUTION

Upper support fixture is heavy. To prevent injury to installer and damage to Liftgate, use hoist to hold support fixture during removal.

1. Stow the platform (FIG. 22-1). Refer to **Operation Manual** for detailed operating instructions.

2. Position hoist to hold upper support fixture in place as shown in FIG. 22-1.

3. Unbolt the upper support fixture from the LH column (FIG. 22-1A). Repeat for RH column. Then, remove upper support fixture from work area and move the hoist away from vehicle.

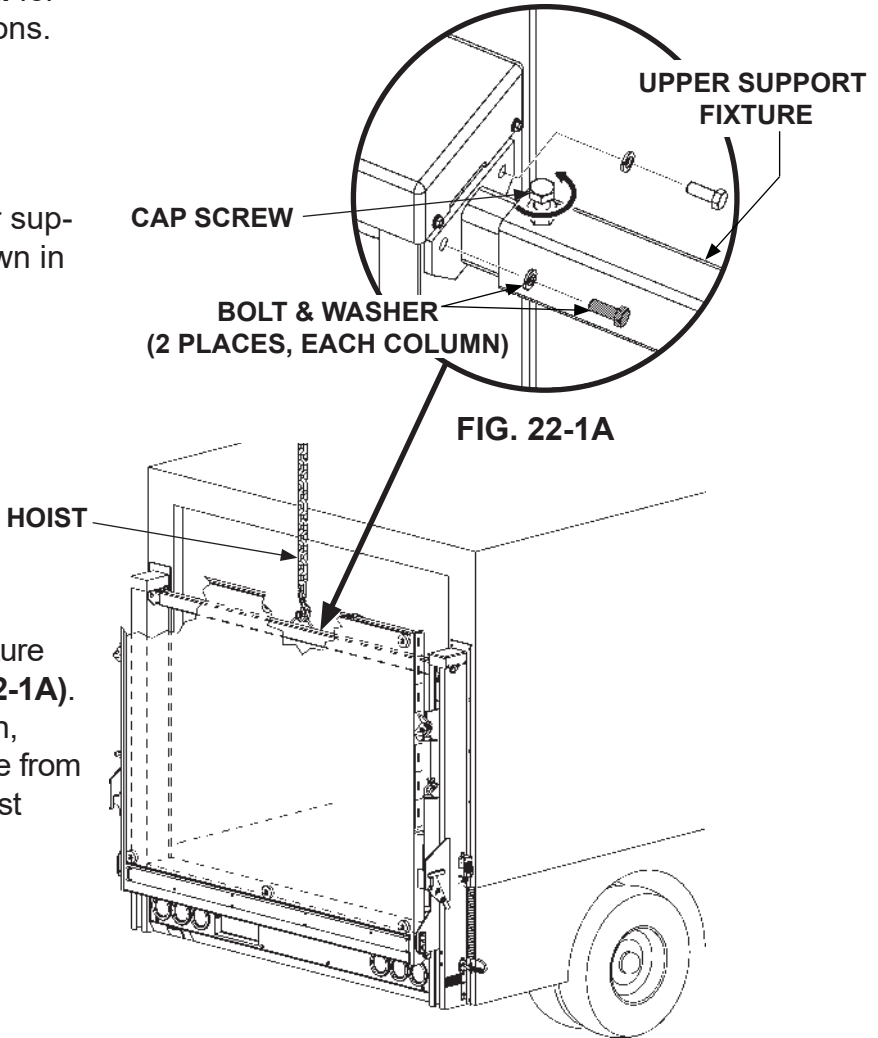

UNBOLTING UPPER SUPPORT FIXTURE
(VIEW OF LH COLUMN AND SUPPORT FIXTURE)

FIG. 22-1

DECALS

NOTE: Decals are preinstalled at factory.
Decal location shown for reference.

NOTE: Ensure there is no residue, dirt or corrosion where decals are attached.
If necessary, clean surface before replacing decals.

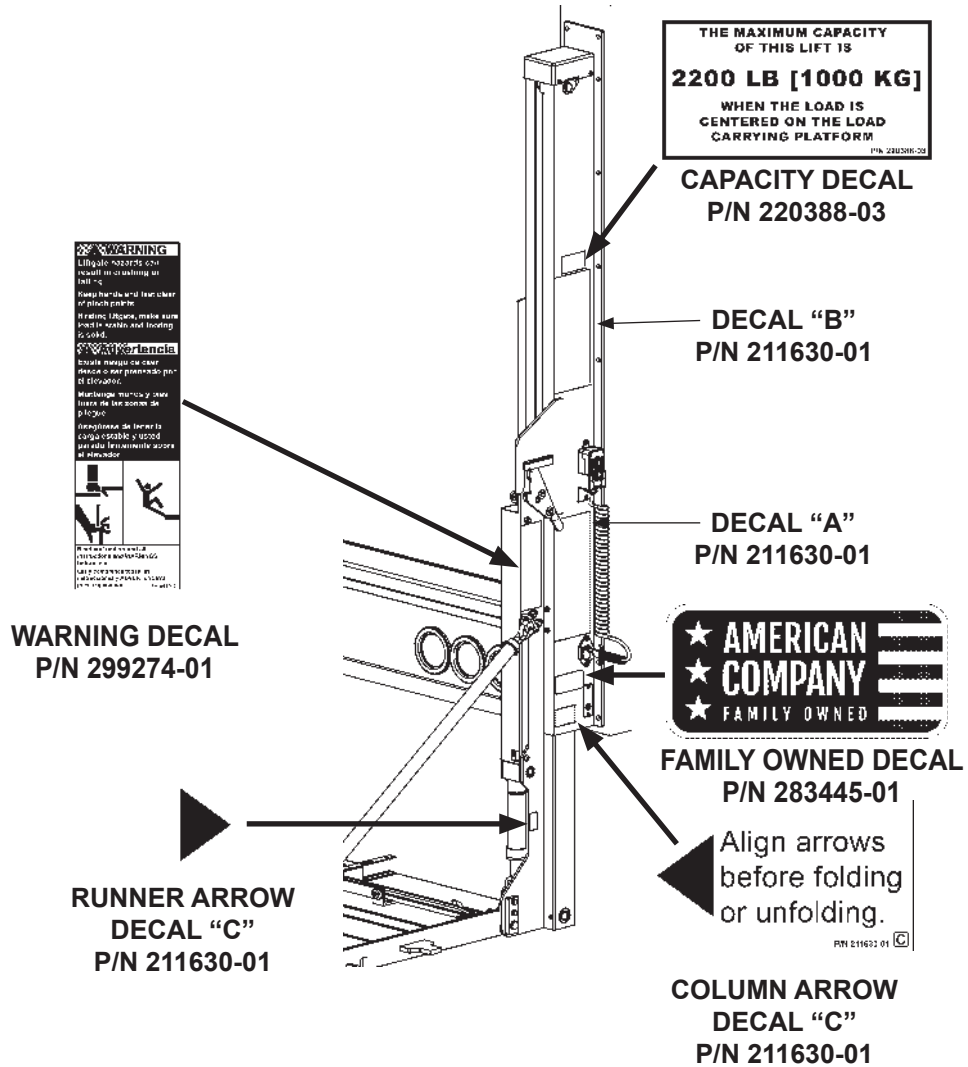

11921 Slauson Ave. Santa Fe Springs, CA. 90670 (800) 227-4116 FAX (888) 771-7713
MAXON

DECALS - Continued

OPERATING INSTRUCTIONS

DMD

Scan this QR code to see operation manual or video.

OPERATE	STOW
1. RAISE PLATFORM OFF TRANSIT HOOK. LOWER TO UNLOCK. <p style="font-size: 8px;">① HAND HELD CONTROL</p>	FOLD & LOCK FLUPOVER IF EQUIPPED. <p style="font-size: 8px;">①</p>
LOWER PLATFORM AT OR BELOW ARROW ALIGNMENT. <p style="font-size: 8px;">②</p>	RAISE PLATFORM AT OR BELOW ARROW ALIGNMENT. <p style="font-size: 8px;">②</p>
TO UNFOLD PLATFORM: PUSH POWER CLOSER BUTTON & LOWER BUTTON AT SAME TIME. <p style="font-size: 8px;">③</p>	TO FOLD PLATFORM: PUSH POWER CLOSER BUTTON & RAISE BUTTON AT SAME TIME. <p style="font-size: 8px;">③</p>
UNLOCK & UNFOLD FLUPOVER. <p style="font-size: 8px;">④</p>	RAISE PLATFORM ABOVE TRANSIT HOOK. <p style="font-size: 8px;">④</p>
RAISE / LOWER PLATFORM. <p style="font-size: 8px;">⑤</p>	MAKE SURE TRANSIT HOOK RETURNS TO TRANSIT POSITION. <p style="font-size: 8px;">⑤</p>

▶ ◀ Align arrows before folding or unfolding.

P/N 21630-01 (C)

CAUTION

Always stand clear of platform area.

WARNING

Liftgate hazards can result in crushing or falling.

Keep hands and feet clear of pinch points.

If riding liftgate, make sure load is stable and footing is solid.

Read and understand all instructions and WARNINGS before use.

WARNING

Read this information carefully.

- Improper operation of this Liftgate can result in serious personal injury. If you do not have a copy of the operating instructions, please obtain them from your employer, distributor, or lessor before you attempt to operate Liftgate.
- If there are signs of improper maintenance, damage to vital parts, or slippery platform surface, do not use the Liftgate until these problems have been corrected.
- If you are using a pallet jack, be sure it can be maneuvered safely.
- Do not operate a forklift on the platform.
- Do not allow any part of yours or your helper's body to be placed under, within, or around any portion of the moving liftgate, or its mechanisms, or in a position that would trap them between the platform and the ground or truck when the Liftgate is operated.
- If a helper is riding the platform with you, make sure you are both doing so safely and that you are not in danger of coming in contact with any moving or potentially moving obstacles.
- **USE GOOD COMMON SENSE**
- If load appears to be unsafe, do not lift or lower it.

For a free copy of other manuals files, specific to this model Liftgate, please visit our website at www.maxonlift.com or call Customer Service at (800) 227-4116.

SAFETY INSTRUCTIONS

Read all decals and operation manual before operating liftgate.

1. Do not use liftgate unless you have been properly instructed and have read, and are familiar with, the operating instructions.
2. Be certain vehicle is properly and securely braked before using the liftgate.
3. Always inspect this liftgate for maintenance or damage before using it. Do not use liftgate if it shows any sign of damage or improper maintenance.
4. Do not overload.
5. Make certain the area in which the platform will open and close is clear before opening or closing the platform.
6. Make certain platform area, including the area in which loads may fall from platform, is clear before and at all times during operation of liftgate.
7. This liftgate is intended for loading and unloading of cargo only. Do not use this liftgate for anything but its intended use.

P/N 21630-01 (A)

DECAL SHEET
P/N 211630-01

MAXON® 11921 Slauson Ave. Santa Fe Springs, CA. 90670 (800) 227-4116 FAX (888) 771-7713

DECALS & PLATES

NOTE: Preferred decal layout is shown. Decals on the Liftgate are attached at the factory, except for the 24/7 SUPPORT decal. The 24/7 SUPPORT decal is placed at customer's or installer's preference.



**MAXON 24/7
SUPPORT DECAL
P/N 298634-01**

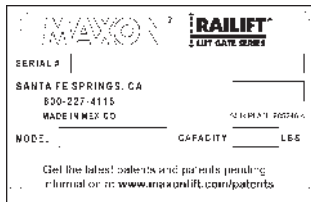

**SERIAL PLATE
(REF)**



**PARTS QR CODE
DECAL
P/N 299143-01**

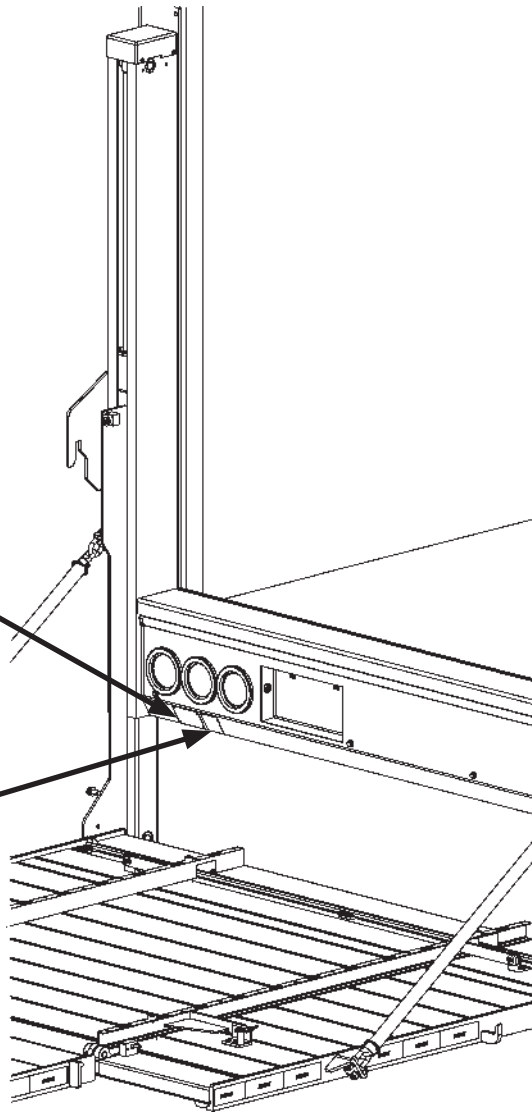
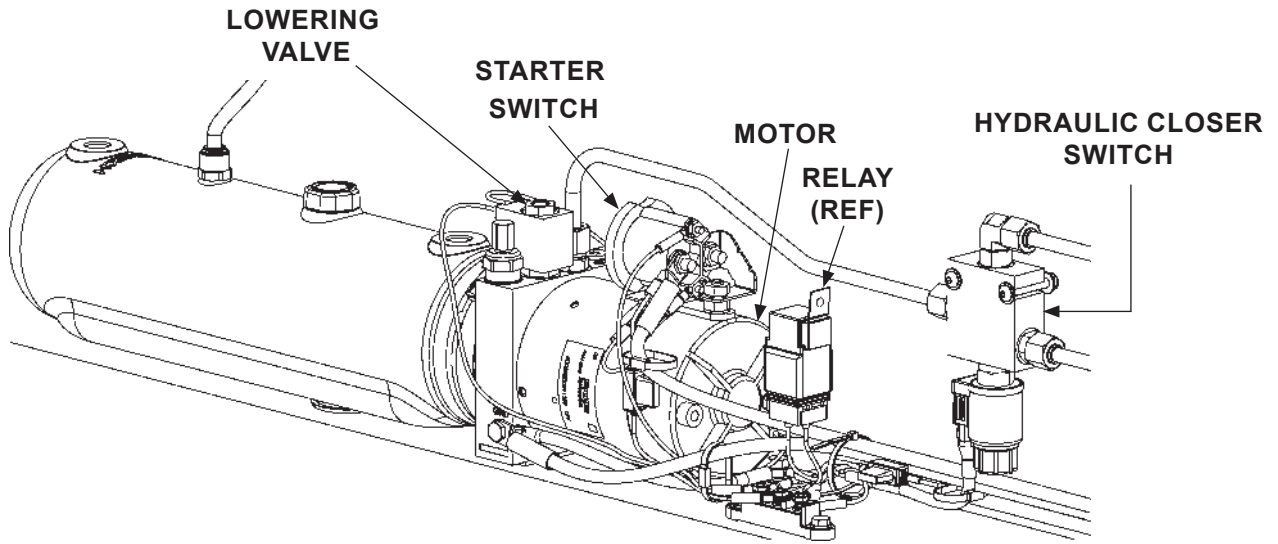

FIG. 25-1

SYSTEM DIAGRAMS

PUMP MOTOR & VALVE OPERATION



POWER UNIT
FIG. 26-1

POWER UNIT MOTOR & VALVE OPERATION			
LIFTGATE FUNCTION	REMOTE VALVE OPERATION (✓ MEANS ENERGIZED)		
	MOTOR	LOWERING VALVE	HYDRAULIC CLOSER SWITCH
RAISE	✓		
LOWER		✓	
UNFOLD		✓	✓
FOLD	✓		✓
REFER TO VALVES SHOWN ON HYDRAULIC SCHEMATIC			

TABLE 26-1

SYSTEM DIAGRAMS

HYDRAULIC SCHEMATIC

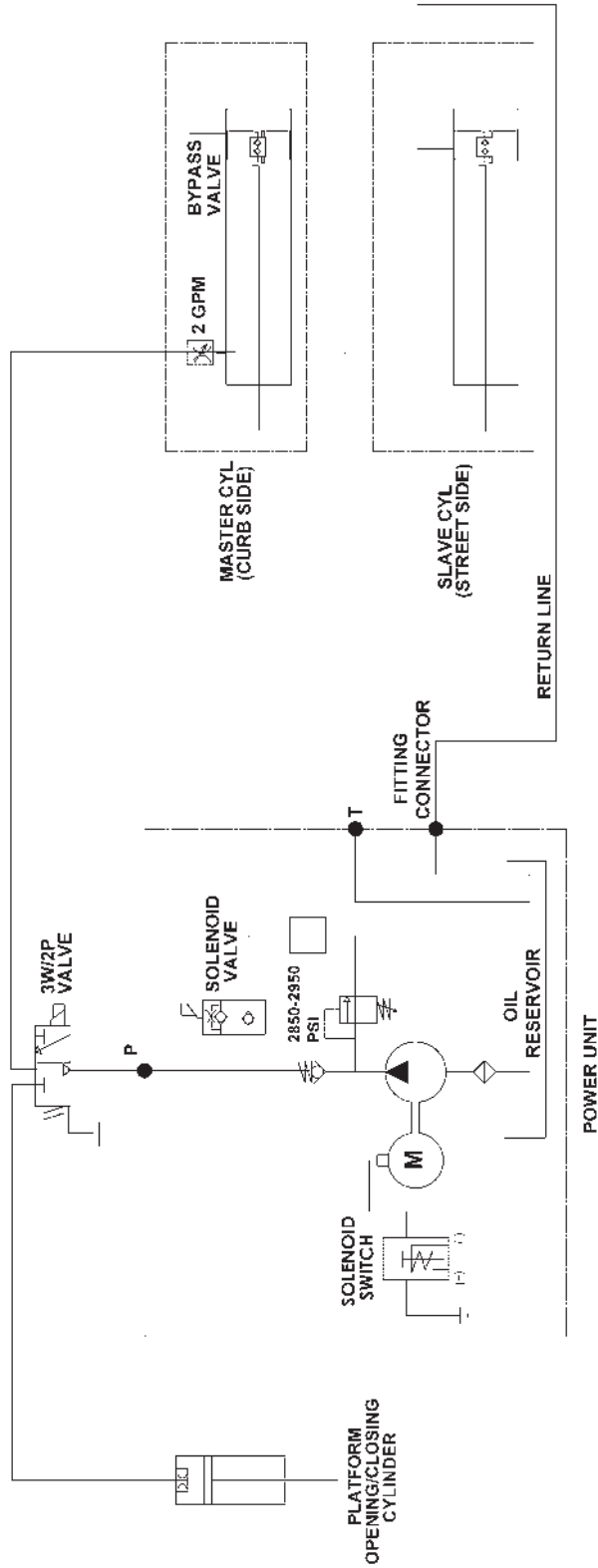

FIG. 27-1

SYSTEM DIAGRAMS ELECTRICAL SCHEMATIC

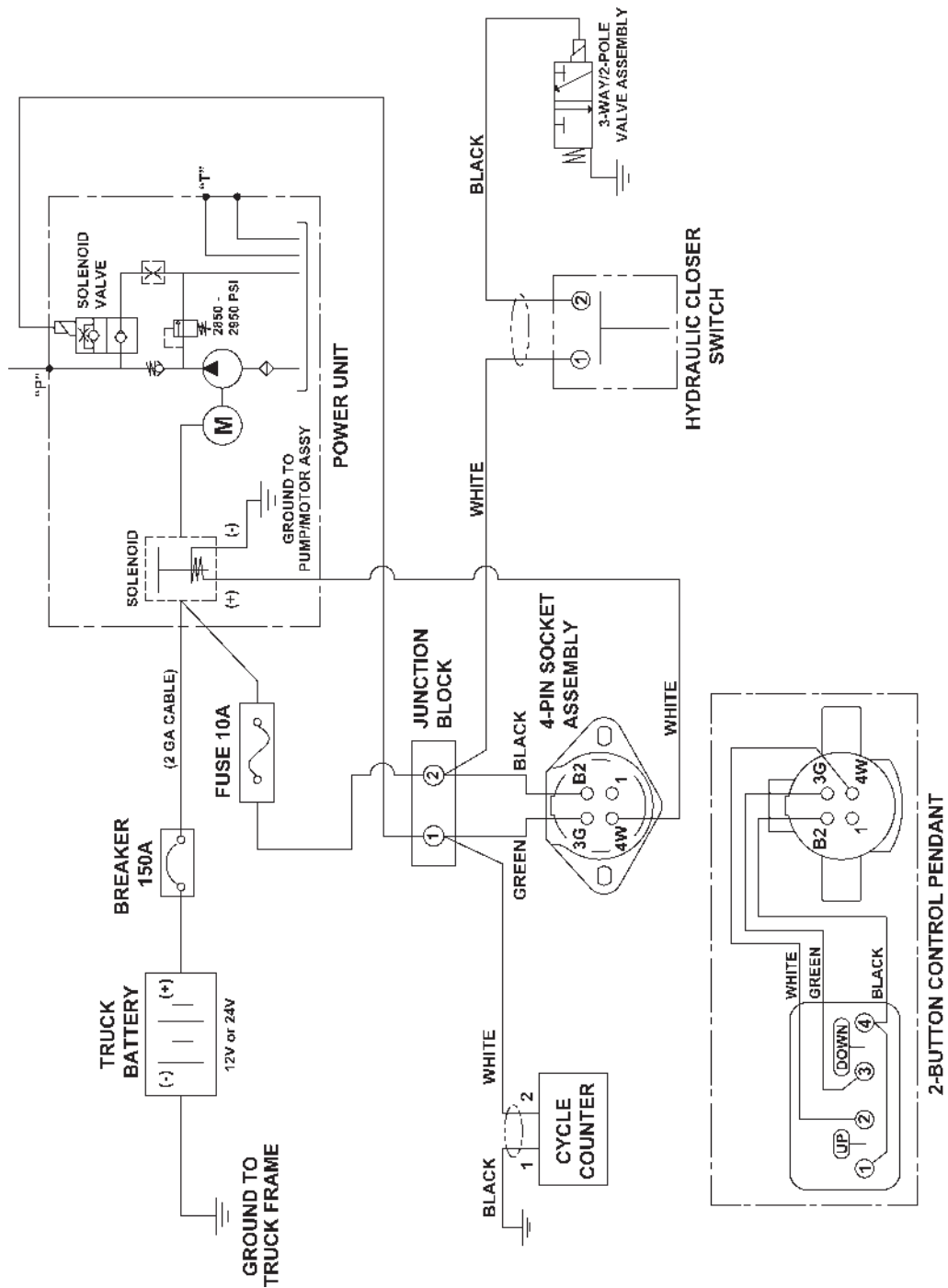

FIG. 28-1

SYSTEM DIAGRAMS

ELECTRICAL SCHEMATIC (ABOVE BED MODEL)

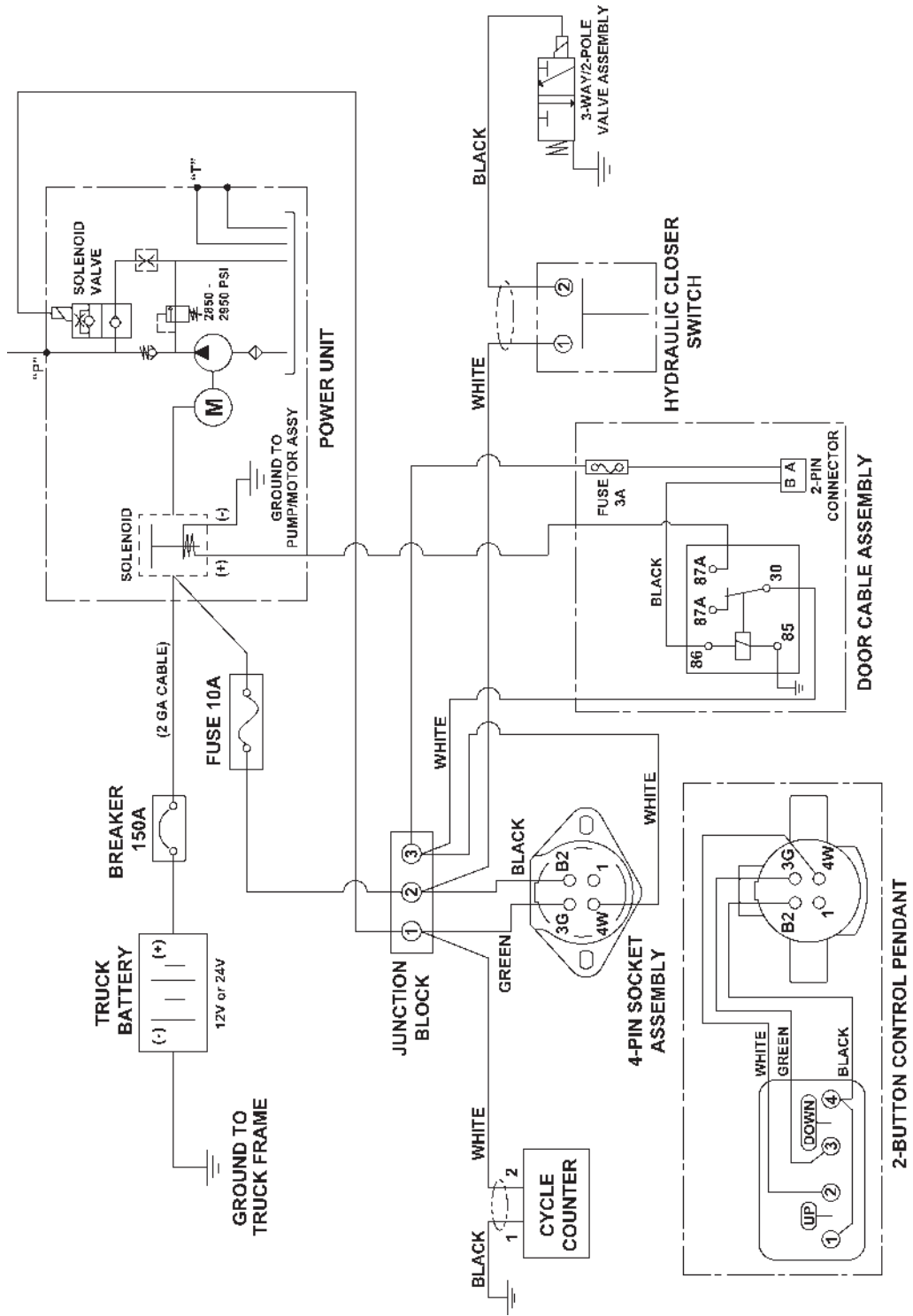

FIG. 29-1

SYSTEM DIAGRAMS

ELECTRICAL SCHEMATIC - JUMPER HARNESS ASSEMBLY

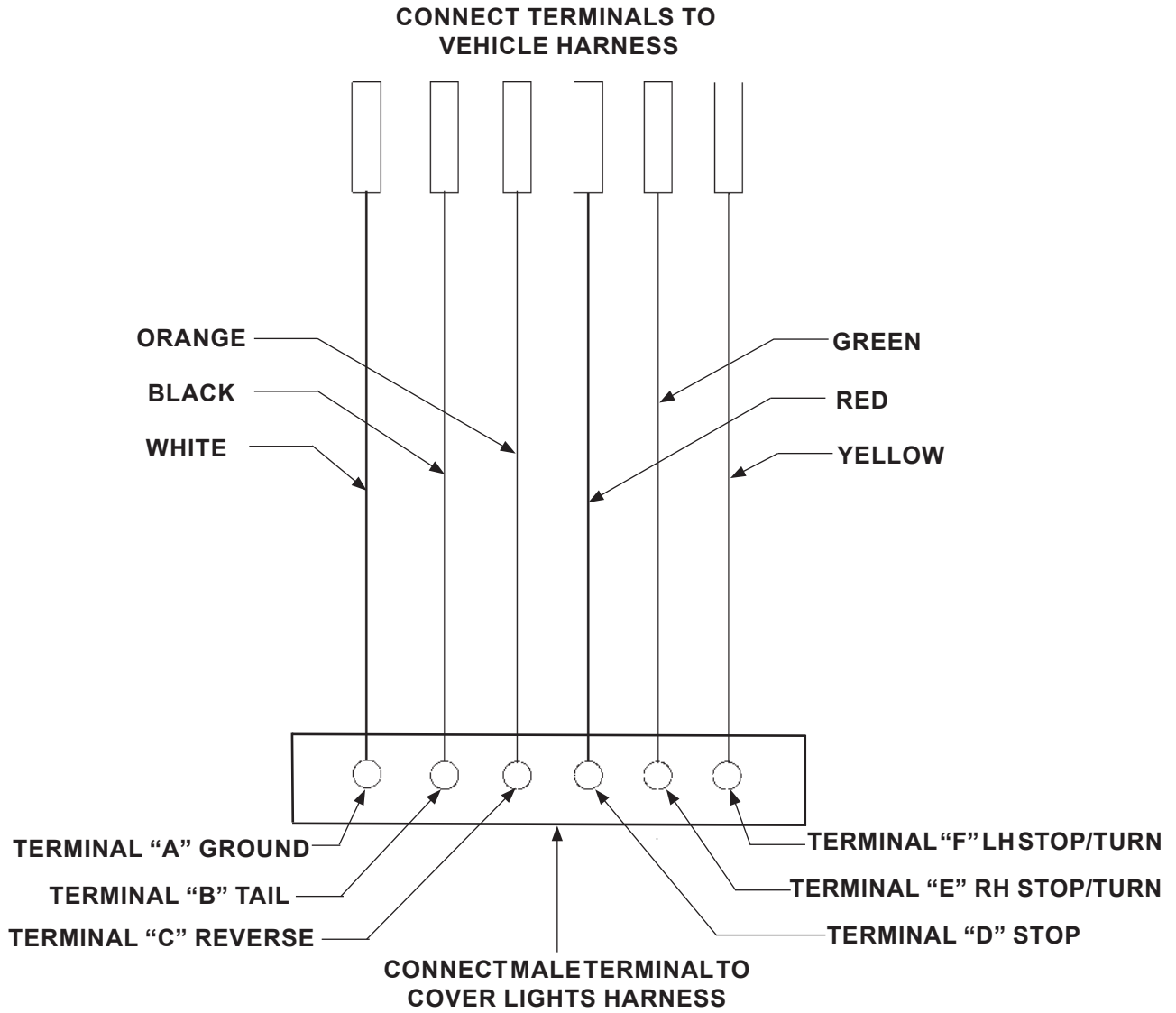

FIG. 30-1

SYSTEM DIAGRAMS

DMD ELECTRICAL VALUES & TORQUE SPECIFICATIONS

SOLENOID SWITCH	12V	24V
Coil resistance:	5.4Ω @70°F. ±15%	20.1Ω @70°F. ±15%
Ampere:	2.2A	1.2A
Coil terminal torque: 10-15 lb-in max.		
Contact terminal torque: 30-35 lb-in max.		
LOWERING VALVE		
Coil resistance:	6.6Ω @ 70°F. ±15%	26.7Ω @ 70°F. ±15%
Ampere:	1.8A	0.9A
Coil terminal torque: 15-45 lb-in max.		
Valve cartridge torque: 25-30 lb-ft max.		
Coil nut torque: 15-45 lb-in		
HYDRAULIC CLOSER SWITCH		
Coil resistance:	8.0Ω @ 70°F. ±15%	30Ω @ 70°F. ±15%
Ampere:	1.5A	0.8A
Coil terminal torque: 3-4.5 lb-ft max.		
Valve cartridge torque: 18.5-22 lb-ft max.		
GROUND CABLE		
Cap screw torque: 24 lb-ft max.		
CYCLE COUNTER		
Operation voltage	7V - 30V	7V - 30V
150 AMP CIRCUIT BREAKER		
1/4"-20 nut torque: 50 lb-in max.		

TABLE 31-1

MAXON®

PRE-DELIVERY INSPECTION FORM

Important! This pre-delivery checklist is to aid the installer in confirming the proper installation of this Maxon product. It is not a comprehensive list and does not replace the use of the installation manual. The installer is responsible for following all instructions in the installation manual.

Model: _____

Date: _____

Serial Number: _____

Technician: _____

Pre-Installation Inspection:

- Correct model
- Correct capacity
- Correct platform size
- Manuals & decals

Structural Inspection:

- Inspect alignment of final assembly
- Inspect pump box secure mounting
- Inspect all installation welds
- Check roll pins, bolts and fasteners
- Check for no twists in chain (if applicable)
- Inspect tightness of hardware used to secure liftgate to vehicle.
- Ensure ramp on flipover touches ground when runner is 1" above ground, and platform & flipover are level & touching the ground.

Hydraulic Inspection:

- Proper fluid level (See **CHECKING HYDRAULIC FLUID** step in this manual.)
- Check hydraulic fittings in pump box for leaks
- Check hydraulic line connections for leaks

Electrical Inspection:

- Above-Bed DMD Only:** Upgrade starter solenoid is installed on Liftgate power unit. Door cable assembly is connected to power unit and vehicle.
- Check power/charge plug and terminal
- Check for tight wire connections
- Circuit breaker (150A) installed in battery box.
- Ensure batteries are fully charged, all cable connections are tight & tie-downs are tight.
- Inspect all solenoid connections
- Check all wiring harness connections
- Handheld control is plugged in connector on RH runner for operation, or stowed in vehicle when liftgate is not being used.
- Check electrical cable connections (at the bottom of the curb-side runner) are tight & secure.

Operation Inspection:

NOTE: The following times are for 54" bed height, aluminum platform and flipover, Exxon Unis HVI-13 oil, & temperature at 79°F. Times are for reference only and may vary for larger platforms, smaller platforms, or temperature changes.

- Liftgate operates correctly with handheld control switches and power closer switch.
- Above-Bed DMD Only:** Liftgate will operate only if rear doors are closed or opened all the way.
- Unloaded platform lowers in **19 to 34 sec.**
- Unloaded platform raises in **12 to 32 sec.**
- Platform unfolds in **6 to 8 sec.**
- Platform folds in **4 to 6 sec.**
- Unloaded platform raises and lowers evenly. Maximum 1" difference of runners from side to side.
- Platform stows securely on transit latches.
- Cycle counter indicates total number of up and down cycles and adds 1 more count each time platform is raised and lowered.
- Decals in correct location and legible

Verify all lights are operational

- Taillights, stop lights, turn lights, and backup lights turn **ON** and **OFF** correctly.

11921 Slauson Ave. Santa Fe Springs, CA. 90670 (800) 227-4116 FAX (888) 771-7713

MAXON®

