

TM

# CAMERA WASH

U.S. Patents 6,554,210 & 6,199,773

## Installation Guide

MSF8470037004A

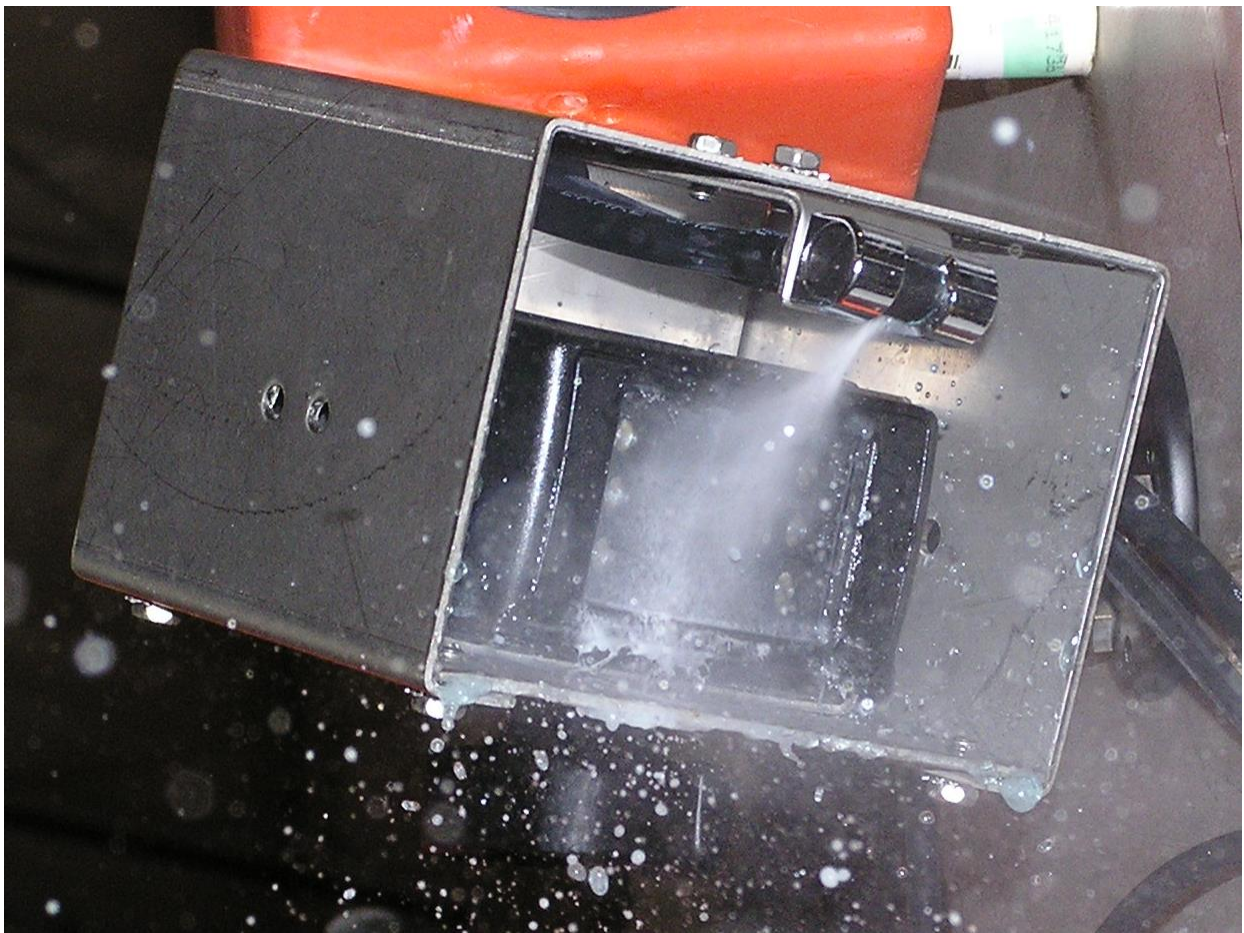

Another Convenience Product from

**M. S. Foster & Associates, Inc.**

1040 Indiana Highway 212, Michigan City, IN 46360  
Phone 219-879-9225 • Toll Free 888-452-4053  
Fax 219-879-9313 • email: [sales@msfoster.com](mailto:sales@msfoster.com)  
[www.msfoster.com](http://www.msfoster.com)

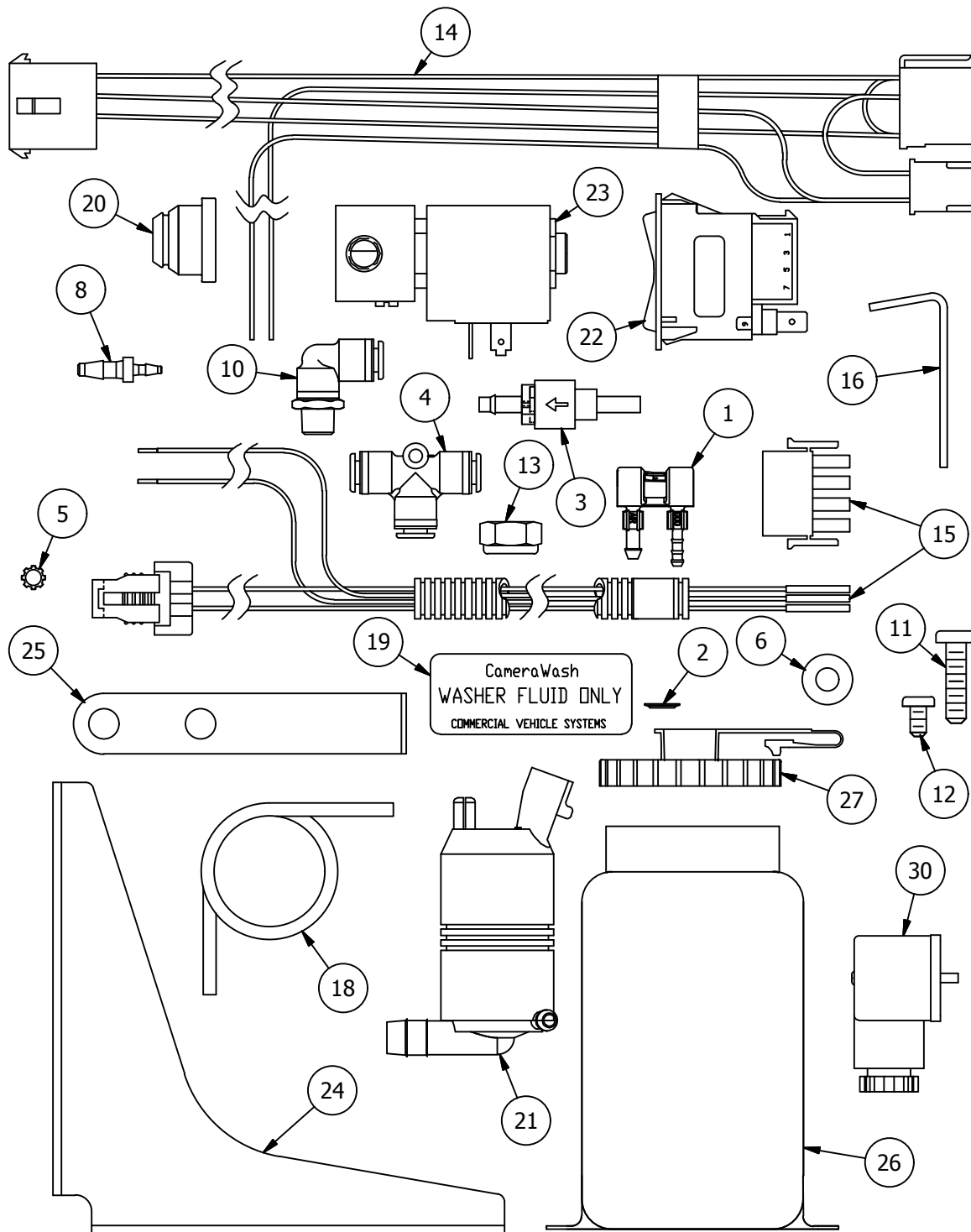

PARTS LIST		
ITE	QT	DESCRIPTION
1	1	ASSEMBLY, NOZZLE, ADJUSTABLE
2	2	NUT, PUSH-ON RETAINER
3	1	VALVE, IN-LINE CHECK
4	1	FITTING, TEE, 1/4" D.O.T.
5	2	WASHER, #10 EXTERNAL STAR
6	4	WASHER, 1/4" FLAT
8	1	FITTING, REDUCER, 5/32" TO 3/32"
10	2	FITTING, ADAPTER ELBOW, 1/8" NPT 1/4" TUBE
11	10	BOLT, 1/4"-20 X 1"
12	2	SCREW, #8-32 X 1/2", PAN HEAD
13	10	NUT, 1/4"-20, SELF- LOCKING
14	1	WIRE HARNESS, CAMERAWASH, SWITCH
15	1	WIRE HARNESS, CAMERAWASH, WASHER PUMP
16	1	BRACKET, NOZZLE MOUNTING
18	1	TUBING, .100 I.D., RUBBER, 18"
19	1	LABEL, RESERVOIR
20	1	GROMMET, WASHER PUMP
21	1	PUMP
22	1	SWITCH, ROCKER, 12V, CAMERAWASH
23	1	VALVE, SOLENIOD
24	2	BRACKET, SUPPORT, RESERVOIR
25	1	BRACKET, SUPPORT, PUMP
26	1	RESERVOIR, 1 GALLON
27	1	COVER, RESERVOIR
28	--	INSTALLATION MANUAL, CAMERAWASH
29	1	LABEL, TRADEMARK
30	1	CANFIELD CONNECTOR B12

NOTE: 1. WHEN USED WITH S.S. CAMERA BOX;  
REMOVE ITEMS 1, 2, 8, 16, & 18  
FROM KIT PRIOR TO SHIPPING

2. ITEMS 28 AND 29 NOT SHOWN

# Installation Instructions

## CAMERAWASH™

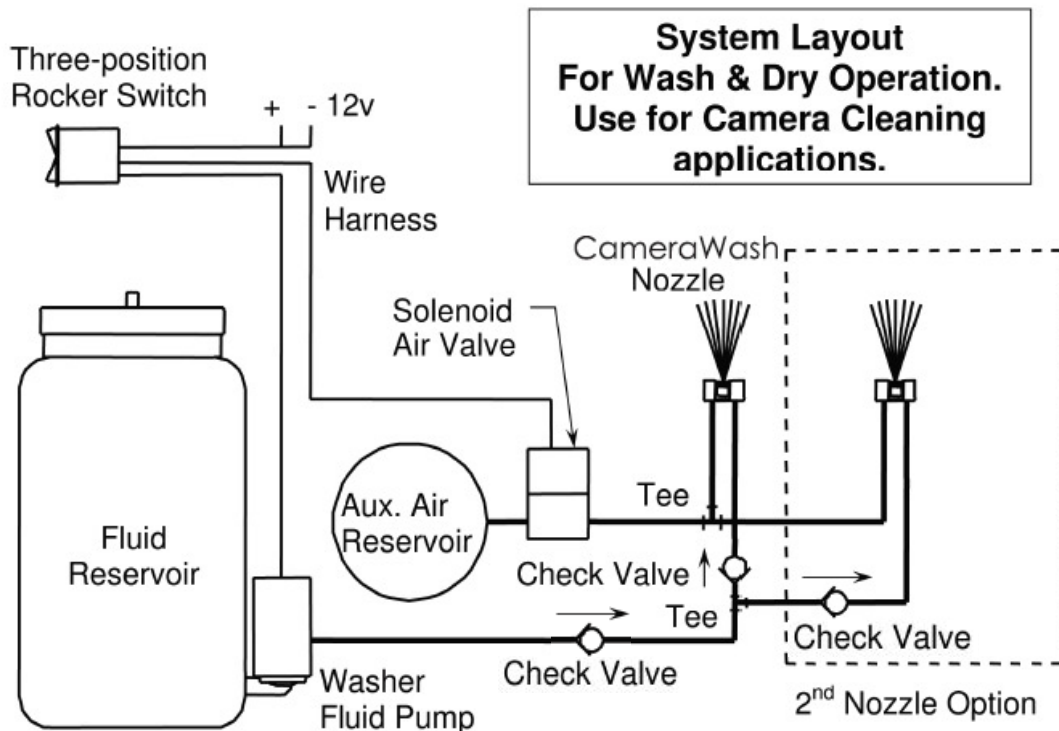

These instructions describe the installation of an independent fluid and air cleaning system for vehicle-mounted cameras.

### Required Tools

- 8mm or 5/16" hex deep socket only ( for installing nozzle retainer washers)
- Tubing Cutter (or *sharp* Utility Knife)
- Phillips head screw driver
- Flat screw driver, 5/16 wide, in good condition for nozzle adjustment, or right angle flat screw driver.
- Portable drill with bits
  - 3/32 inch bit
  - 7/32 inch bit
  - 9/32 inch bit
- Center Punch
- Socket and drive set
- Wire Terminal Crimp Tool

# Installation Instructions

## CAMERAWASH™

- Step 1. **RESERVOIR:** Locate an area where you can mount the 1-gallon Fluid Reservoir. It should be mounted in an area that is easily accessible for refilling, away from direct impact of tire debris, such as rocks, etc., and away from high heat sources such as engine exhaust. If possible, mount it near the cab to keep the electrical wiring within reach of the harness that is supplied.

**NOTE:** Make sure that the necessary clearance is available above the reservoir for filling.

- Step 2. Once you have determined your mounting location, use a center punch to mark the hole locations. Use the Reservoir as a template for the mounting holes in order to prevent misalignment. (The Mounting Brackets and the Reservoir use the same hole spacing).

- Step 3. Drill four (4) mounting holes with a 9/32" drill. It may be necessary to drill a small (3/32") pilot hole first. Use of cutting oil is recommended.

**NOTE:** *Be sure to check behind the mounting surface for wiring, hydraulic lines, or tubing before drilling. You may need to pull away tubing or wiring to allow clearance for drilling.*

- Step 4. Fasten the Mounting Brackets using 3 of the 1/4-20 Bolts provided, on the vertical face of the brackets.

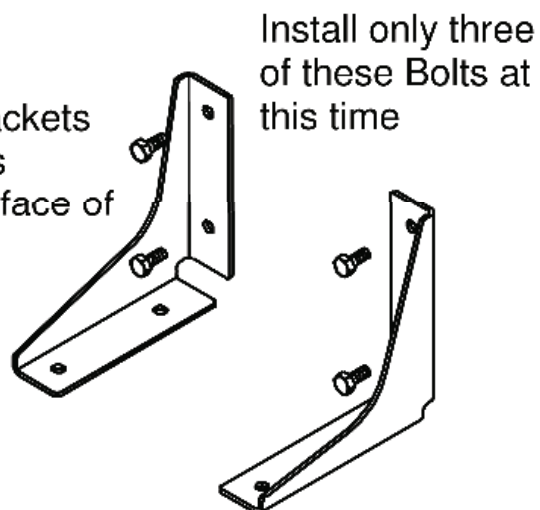

# Installation Instructions

## CAMERAWASH™

**NOTE:** Leave the top Bracket hole open on the side of the Reservoir where the Pump will be installed. Note that the Pump can be installed on either side of the Reservoir (see below).

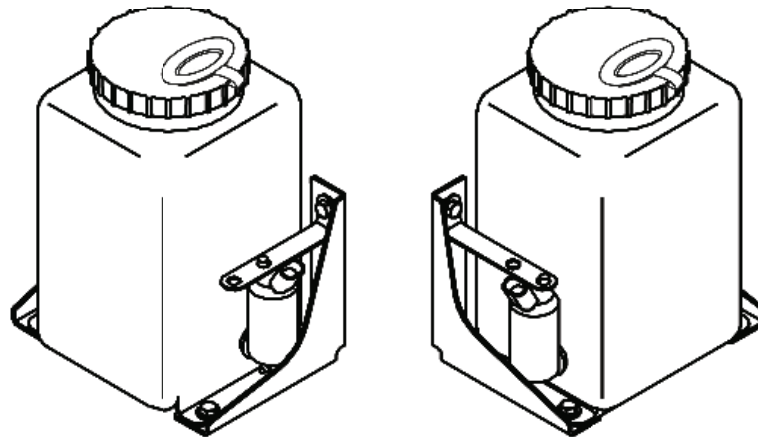

- Step 5. Fasten the Reservoir to the Mounting Brackets using 4 of the 1/4-20 Bolts provided. Be sure to place the Flat Washers between the plastic Reservoir and the Bolts.

- Step 6. Insert the Grommet, then the Pump into the Reservoir. Use water as a lubricant to aid in insertion.

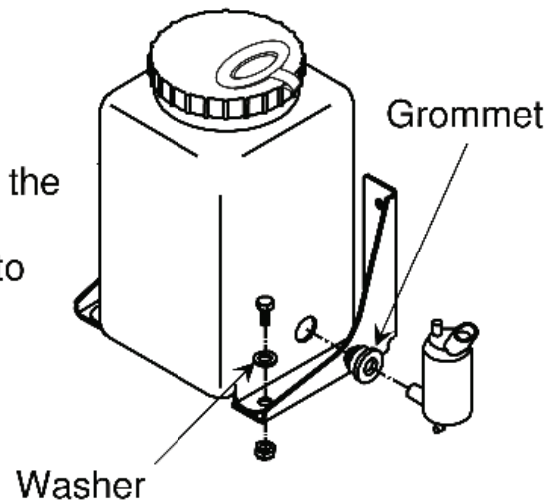

- Step 7. Mount the supplied Pump Support Bracket using the last 1/4-20 Bolt provided.

# Installation Instructions

## CAMERAWASH™

- Step 8. **Air Solenoid Valve** : Mount the Air Solenoid Valve in a convenient location, such as to the Reservoir Bracket. It may be mounted in any position. Drill two (2) 7/32" holes per the dimensions shown. Attach using the 10-32 X 3/8" Mounting Screws and Lock Washers supplied.

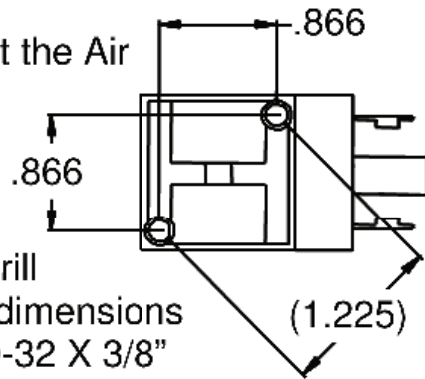

**Solenoid Hole Pattern**

- Step 9. Route 1/4" Nylon Air Line from the secondary air supply to the Solenoid. Use the Tee Fitting supplied to connect to an existing 1/4" line. Insert the tubing into the push-to-connect fitting (Port A) on the Solenoid. See below for tubing handling.

**Nylon Tubing Handling:** Prior to installation, the tubing end **MUST** be clean and free of contamination, with no nicks or burrs for the first 1/2". The air tubing is supplied in this condition. When length adjustments need to be made, the tubing should be cut-off clean and square to the length, using a sharp utility knife or a tubing cutter. *Do Not Use Pliers.*

- **To install the tubing:** push the tubing into the fitting approximately 5/8" and "bottom out"

### **Tubing Installation**

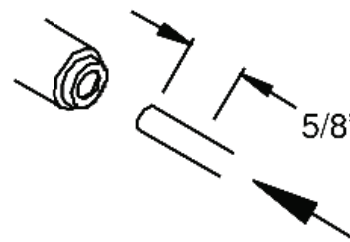

- **To remove the tubing:** with air supply off, hold the plastic Push-To-Release button TIGHT against the Valve, and while holding in, pull the tubing out.

### **Tubing Removal**

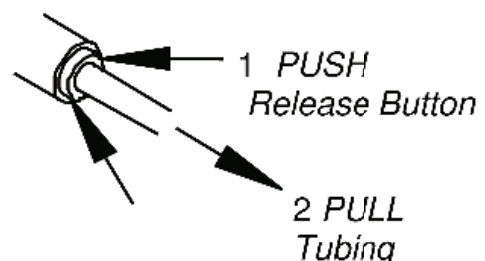

# Installation Instructions

## CAMERAWASH™

Step 10. Route the air and fluid delivery lines from the Reservoir and Solenoid to the Nozzle location. Avoid sharp edges and kinks. Route so as to avoid tubing damage during normal use.

Step 11. **Nozzle Location:** The Nozzle can be aimed up, down, or sideways. The Nozzle must be within 4 inches of the lens, and 1" to 2" ahead of it. The spray should be aimed near the center of the camera lens, avoiding directly impacting microphone or speaker openings.

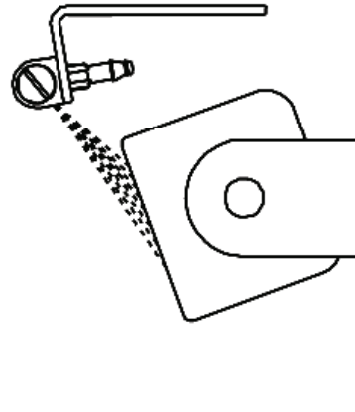

Step 12. **Nozzle Adjustment:** The Nozzle spray direction is adjustable over 125°. Pre-adjust the Nozzle before installing to spray in the direction needed. Always use a 5/16" wide, flat head screwdriver (in good condition) to adjust the Nozzle.

Hold the Nozzle securely, against a solid surface and turn slowly, applying generous downward force to prevent the bit from slipping out of the slot.

**Adjustable  
Spray  
Direction**

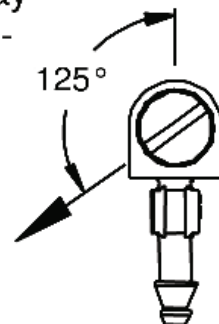

## Installation Instructions CAMERAWASH™

- Step 13. Insert the Nozzles into the Nozzle Bracket. Position the Nozzles so that the fluid and air outlets are facing the camera. You may need to access the adjustment slot later, so make sure it is easily accessible.

***Once the Retainers are installed, they cannot be reused.***

To install them, use a 5/16" or 8mm hex deep socket; push the Retaining Washers onto the Nozzle hose barbs until the Nozzle fits snuggle onto the bracket. Attach the bracket to the vehicle.

Up to four (4) Nozzles may be operated from one Pump and Solenoid pair. If additional Nozzles are needed, contact M.S. Foster & Associates, Inc

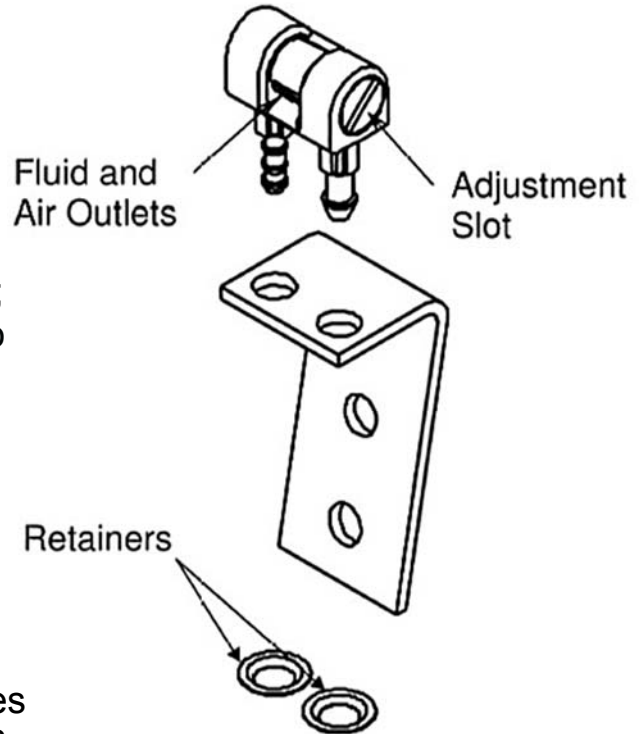

### Nozzle Attachment

- Step 14. Install the 18" piece of 3/32" ID rubber Tubing to the Nozzle fluid fitting. (The fluid fitting has three barbs.) Attach the nylon Tubing to the Nozzle air fitting. The air fitting is shorter, has one single barb, and is label "AIR". Check to make sure that the air and fluid lines are connected to the correct barbs. Install the Check Valves in the larger rubber tubing from the pump. Make sure the arrow is pointing away from the Pump. Install one check valve nearest to nozzle and install the other check valve nearest to the reservoir.

**NOTE:** If more tubing is needed, use .156" (5/32") I.D. Windshield Washer Tubing for the rubber tubing and use 1/4" O.D. SAE J844 Nylon tubing for the air lines.

- Step 15. Switch: Install the switch in the dash. The hole size for the switch is 1.732" x .866" (44mm x 22mm). Panel thickness must be .04" x .10"

### Switch Hole Size

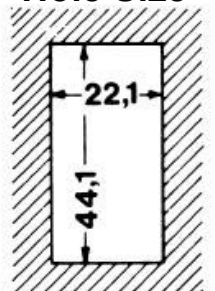

Step 16. **Switch Wire Harness:**  
Connect the loose red (+) wire to a fused circuit (8 to 10 amp). Attach the loose black (-) wire to a clean attachment point. Use the appropriate crimp terminals and tools.

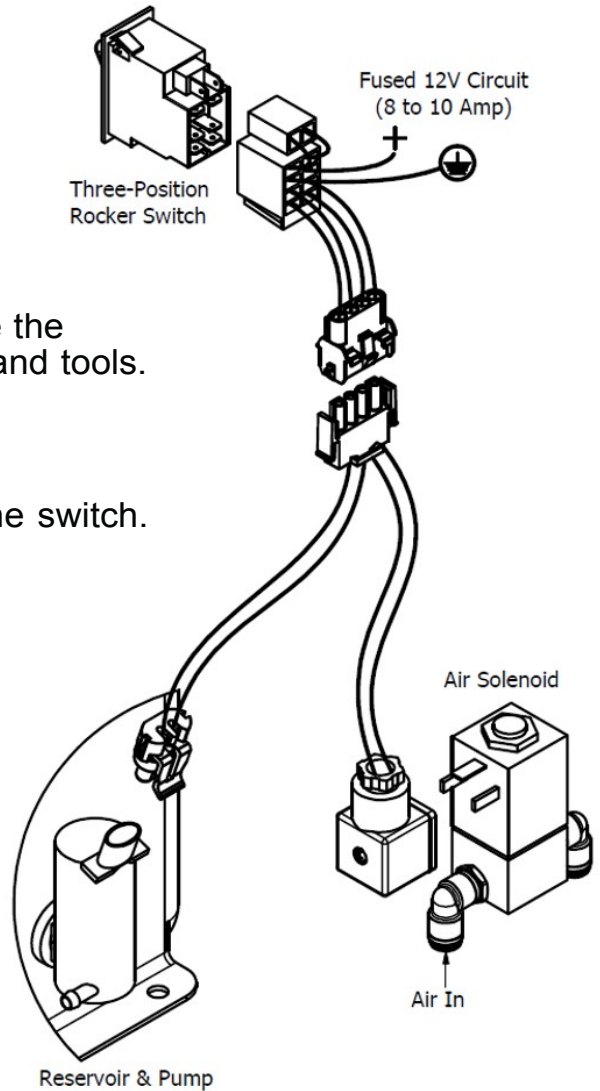

Step 17. Attach the wire harness to the switch.

Step 18. Route the **Pump Harness** from the Pump and Solenoid area to the cab. Feed the pin terminal ends through a grommet (not supplied). Insert the pins into the connector housing using as a guide the mating connector on the Switch Harness.

The green wire goes in socket #1, the black in socket #2, the red in socket #3 and the white in socket #4. Connect the two harnesses.

Step 19. Connect the Harness to the Pump and Solenoid. At the Solenoid Valve, attach the red and white wire connectors to the two terminals that are "C" shaped. (See picture.) It does not matter which wire color goes on which terminal.

# Installation Instructions

## CAMERAWASH™

### System Check

Step 1 The system is now ready to check

Step 2 Make sure the washer bottle is filled with washer fluid.



**WARNING: SOME WASHER FLUIDS CONTAIN POTENTIALLY HAZARDOUS SUBSTANCES. FOLLOW SUPPLIER'S INSTRUCTIONS.**

- Wear safety glasses or goggles at all times when observing Washer Nozzle spray patterns.
- Operate Washer only in a well-ventilated area outdoors.

Step 3 Check to make sure that the vehicle has sufficient air pressure (90 psi or greater)

Step 4 Start the engine and operate the Camera Wash switch in the wash direction. It will take 10 to 20 seconds to prime the system. When the system has primed itself, fluid and air spray will come out the nozzles.

Step 5 Operate the switch in the opposite direction to apply an air blast that removes most of the fluid off of the lens for clearer vision.

Step 6 Adjust the Nozzle if necessary. It will be necessary to have someone activate the system from inside the cab while the Nozzle spray pattern is observed.

Step 7 To adjust the Nozzle, a 5/16" wide flat head screwdriver (in new condition) to raise and lower the pattern. On some installations it may be necessary to use an angled screwdriver.

Step 8 Tie wrap (or tape) the tubing and wire Harnesses so that they are secure and clear of moving parts, including the hinge points of the hood. Make sure that they do not come in contact with hot or moving engine components. It is recommended to fasten the Tubing Harnesses to existing harnesses where possible.

# Installation Instructions

## CAMERAWASH™

### Trouble Shooting

- Step 1      Check to see that the Solenoid Valve and Check Valves are plumbed correctly.
- Step 2      If there is no fluid at the Nozzle:
- Be sure there is washer fluid in the reservoir. Run the washer pump for 15 seconds more to prime the system with fluid.
  - Examine the check valves to see that the arrow on it is pointing toward the nozzle. Operate pump again. If there is no fluid:
    - Check for kinked or pinched tubing.
    - Check that fluid is flowing when the pump is running. If not, the pump may be wired backward. Reverse the + and – wires that supply the switch and check again.
    - Make sure that all connections are properly engaged and are sealing.
  - Check the Nozzle for debris. To clear debris, remove the fluid tubing below the Nozzle, and blow compressed air back through the small Nozzle opening to clear it.
- Step 3      If the Nozzles spray fluid but not air:
- Check the air inlet connection to the Solenoid Valve, to make sure that the Valve is pressurized and plumbed with air supplied to port 2/A.
  - Make sure all air fittings are securely connected.

# Installation Instructions

## CAMERA WASH™

### Wiring Schematic

